

ENVIA TRP

STORAGE TANKS

INFILTRATION

PUMPING STATIONS

GREASE SEPARATORS

OIL SEPARATORS



OIL SEPARATOR – ENVIA TRP

A solution was developed by PURECO for filtering and retaining the contaminants washed away by storm water flowing down from linear engineering structures (roads, motorways, parking lots). This uniquely developed technology is in compliance with the contamination types, economical to install, simple to operate, as well as the retained materials are economically removable. The materials used for constructing the object are extremely durable. The ENVIA TRP is able to meet the task of the primary treatment of storm water with appropriate efficiency and security. Our equipment ensures that the contaminant levels of effluents are within the specified limit values, separated and retained materials are stored safely in time periods between maintenance and cleaning events. It is able to retain and store hazardous waste that may spill onto the pavement in an accident or emergency case, and it prevents damages to and pollution of the natural environment.



The application fields of the equipment

- Installation in open-surface ditches made for the drainage of storm water coming from linear traffic facilities
- An equipment to control the discharge and/or overflow of small reservoirs or lakes that in case of overflow should retain possible floating contaminants.

The technical advantages of the equipment

- Installable also in existing storm water drainage systems,
- Operable without surveillance, minimum maintenance needs,
- High-capacity equipment,
- The process it applies to cause oil drops to flow up and for retainment is well-known, tried, and tested,
- Even without filter materials, it ensures protection against emergencies for any storage tanks with an open surface.

The economic advantages of the equipment

- Lower investment costs than in the case of prefabricated oil separator equipment with a tank.
- Less earth work needed.
- Equipment with variable and wide-scale hydraulic capacities (0-300 l/s).

The materials, and the installation of the equipment

- Made from corrosion proof materials,
- Simple and fast installation with minimum tooling requirements,
- The ex-works price of these equipment is lower than that of traditional, prefabricated separation equipment with tanks
- Robust construction, compact design
- Faster installation – the time it takes to install the equipment is shorter by orders of magnitude.

Name	Article number	Efficiency	Cleaning capacity	Total flow	Height	Width	Length	Weight
5 mg/l SZOE								
ENVIA TRP 60/120	M1A5N	5 mg/l	60 l/s	120 l/s	800 mm	1500 mm	900 mm	1290 kg
ENVIA TRP 75/150	M1B5N	5 mg/l	75 l/s	150 l/s	900 mm	1500 mm	900 mm	1440 kg
ENVIA TRP 90/180	M1C5N	5 mg/l	90 l/s	180 l/s	1100 mm	1500 mm	900 mm	1720 kg
ENVIA TRP 100/200	M1D5N	5 mg/l	100 l/s	200 l/s	1100 mm	1500 mm	900 mm	1660 kg
ENVIA TRP 125/250	D1A5N	5 mg/l	125 l/s	250 l/s	800 mm	2600 mm	900 mm	1840 kg
ENVIA TRP 150/300	D1B5N	5 mg/l	150 l/s	300 l/s	900 mm	2600 mm	900 mm	2020 kg
ENVIA TRP 200/350	D1C5N	5 mg/l	200 l/s	350 l/s	1100 mm	2600 mm	900 mm	2370 kg
ENVIATRP 225/400	D1D5N	5 mg/l	225 l/s	400 l/s	1100 mm	2600 mm	900 mm	2280 kg

Name	Article number	Efficiency	Cleaning capacity	Total flow	Height	Width	Length	Weight
2 mg/l SZOE								
ENVIA TRP 40/80	M2A2N	2 mg/l	40 l/s	80 l/s	800 mm	1500 mm	1350 mm	1780 kg
ENVIA TRP 55/1100	M2B2N	2 mg/l	55 l/s	110 l/s	900 mm	1500 mm	1350 mm	1960 kg
ENVIA TRP 75/150	M2C2N	2 mg/l	75 l/s	150 l/s	1100 mm	1500 mm	1350 mm	2320 kg
ENVIA TRP 85/170	M2D2N	2 mg/l	85 l/s	170 l/s	1100 mm	1500 mm	1350 mm	2260 kg
ENVIA TRP 100/200	D2A2N	2 mg/l	100 l/s	200 l/s	800 mm	2600 mm	1350 mm	2560 kg
ENVIA TRP 125/250	D2B2N	2 mg/l	125 l/s	250 l/s	900 mm	2600 mm	1350 mm	2780 kg
ENVIA TRP 180/320	D2C2N	2 mg/l	180 l/s	320 l/s	1100 mm	2600 mm	1350 mm	3210 kg
ENVIATRP 200/360	D2D2N	2 mg/l	200 l/s	360 l/s	1100 mm	2600 mm	1350 mm	3120 kg

ENVIA BOX drift- and light liquid separator equipment installable to open-surface storm water drainage channels or ditches

ENVIA BOX drift- and light liquid separator equipment installable to open-surface storm water drainage channels or ditches, for 5 mg/l SZOE/TPH limit values for the territorial categories 2. 3. and 4. under Annex 2 of the Regulation 28/2004. (XII. 25.) KvVM.

Article number	Inclusive dimensions			Mass
	H [mm]	B [mm]	L [mm]	m [kg]
ENVIA® BOX D 1 A 5 W 125	500	2000	680	90
ENVIA® BOX D 1 B 5 W 150	600	2000	680	100
ENVIA® BOX D 1 C 5 W 200	800	2000	680	120

ENVIA BOX drift- and light liquid separator equipment installable to open-surface storm water drainage channels or ditches, for 2 mg/l SZOE/TPH limit values for the territorial categories 1. 2. 3. and 4. under Annex 2 of the Regulation 28/2004. (XII. 25.) KvVM.

Article number	Inclusive dimensions			Mass
	H [mm]	B [mm]	L [mm]	m [kg]
ENVIA® BOX D 2 A 2 W 100	500	2000	1000	130
ENVIA® BOX D 2 B 2 W 125	600	2000	1000	150
ENVIA® BOX D 2 C 2 W 180	800	2000	1000	180

Key to the type code:

ENVIA® TRP M 1 A 5 N 60 / 120



Equipment to be fitted into a **TRaP**ezoid section

M = MONO type of equipment

D = DUO (double unit) an equipment of double design

Q = QUATTRO (quadruple units) an equipment of quadruple design



The number of filters: 1 pc. The width of the equipment: 25 cm.

The number of filters: 2 pcs. The width of the equipment: 70 cm.



The height of the weir wall/ Filter insert (cm):

A: 27,5 / 50

B: 35,0 / 60

C: 51,0 / 80

D: 43,5 / 80



for 5 mg/l SZOE/TPH value

for 2 mg/l SZOE/TPH value



Normal design: the weir wall is included by the prefabricated reinforced concrete receiver structure



Nominal treatment capacity (the by-pass line is out of operation); l/s)



Nominal hydraulic capacity (together with the by-pass line); l/s)

DESIGN AID – ENVIA TRP

This Aid provides assistance to designers and investors to enable them to select the most suitable equipment from the ENVIA TRP/BOX product range for their installation site, that best meets the given treatment requirements and other specifications.

This document provides the equipment parameters, and it contains the operations schemes and the installation dimensions.

Please do not hesitate to contact our colleagues with your queries that emerge during the selection process. Our colleagues are entirely at your service: they send the documentation of the equipment to you, even in editable format that can be inserted into drawings; they provide on-site consultation; when and if necessary, they take part in the selection, design, licencing or construction processes.

ENVIA TRP / BOX drift- and light liquid separator equipment installable to open-surface storm water drainage channels or ditches

Before and after the equipment the cross-section of the water-course bed must be paved; we recommend to make the pavement up to the dammed-up water-level. A drift-trap area should be constructed before the equipment, which can be constructed from commercially available bottom-pavement elements, lowered typically below the bottom level of the water course. The required volume is variable in accordance with the contamination levels of the water to be treated, and the types of the contamination.

Recommendation: 10-times the dimensioning value of the input water quantity (calculated in l/s) should be specified (in litres) for the volumes, in the case of public roads and motorways.

Installation sketches for the equipment

Depending on the water quantity flowing through the equipment, and in accordance with the width dimensions, the equipment may be installed as depicted by the following sketches:

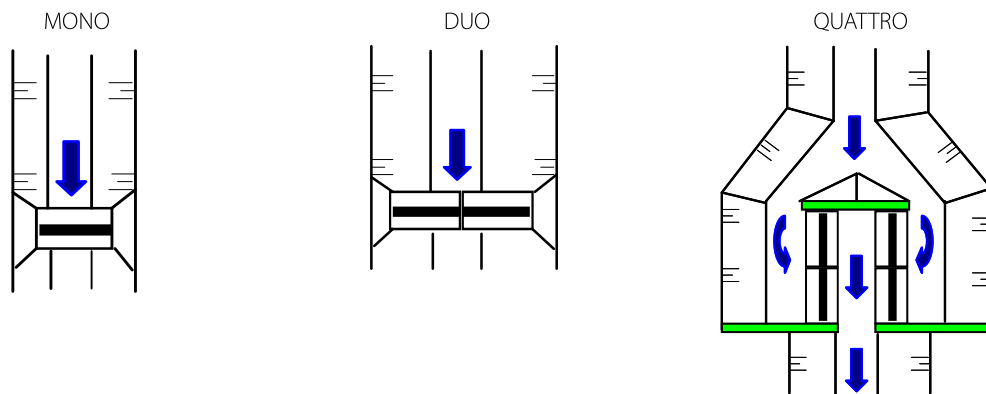

ENVIA TRP SINGLE UNIT INSTALLATION SAMPLE

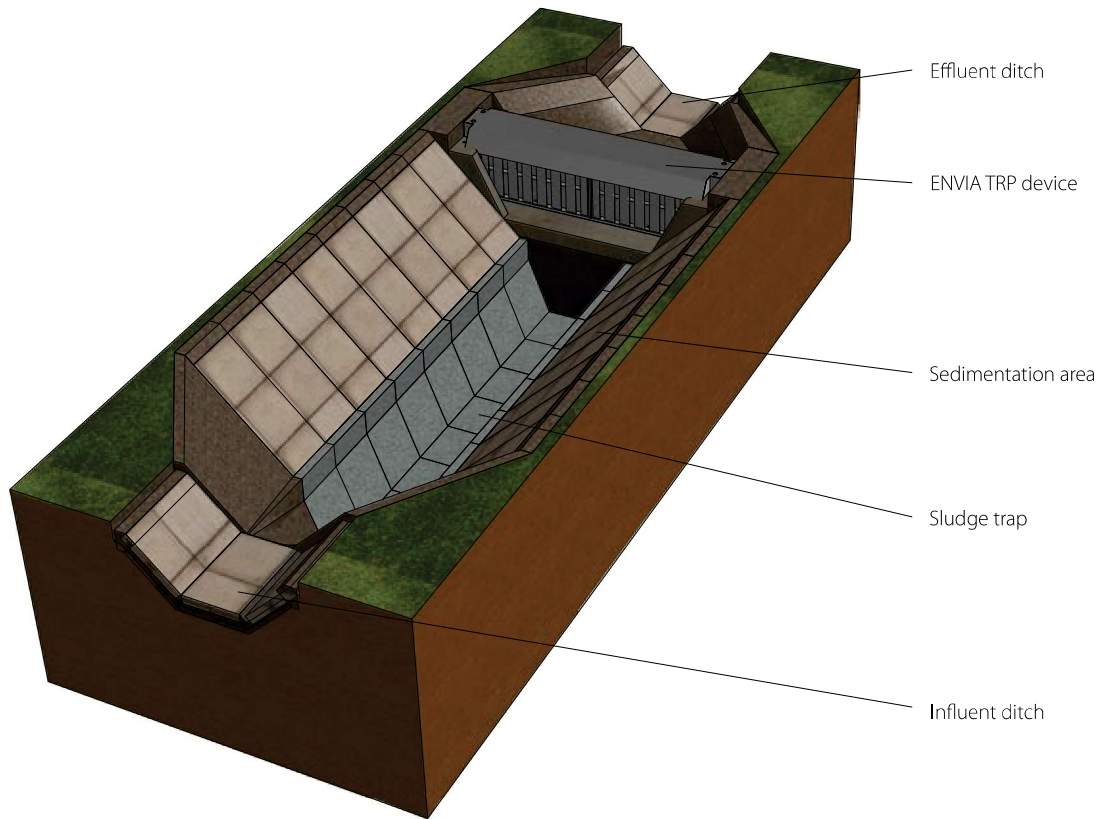

ENVIA TRP MULTIPLE UNITS INSTALLATION SAMPLE

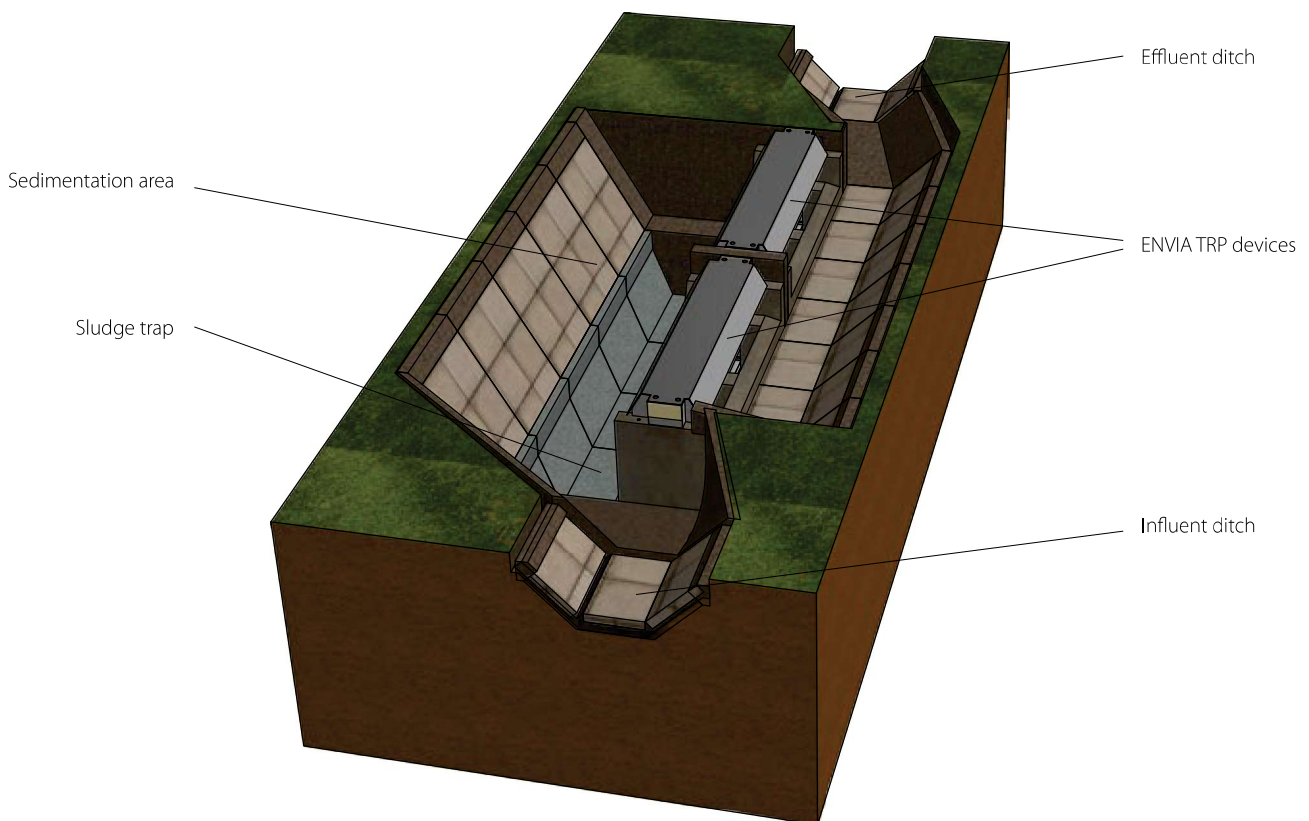

DESIGN AID – ENVIA TRP SINGLE UNIT DESIGN

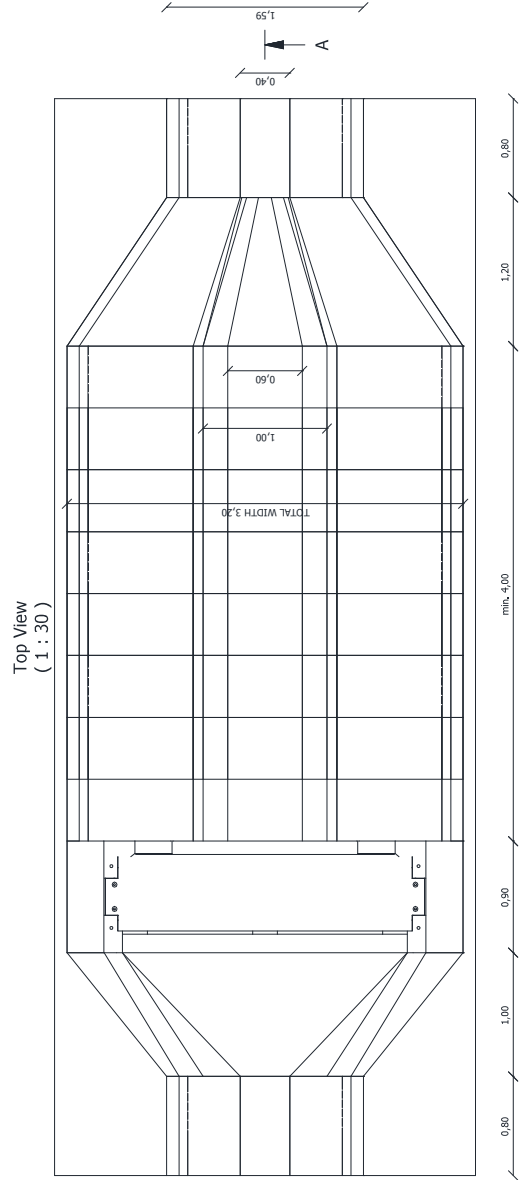
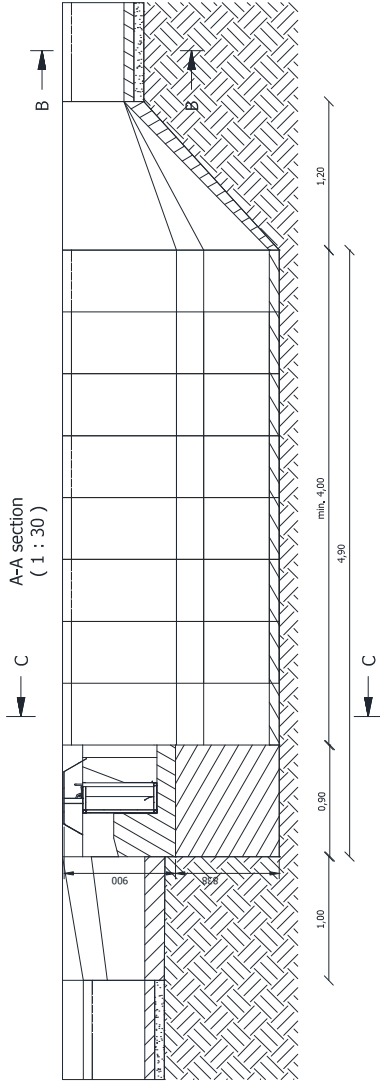
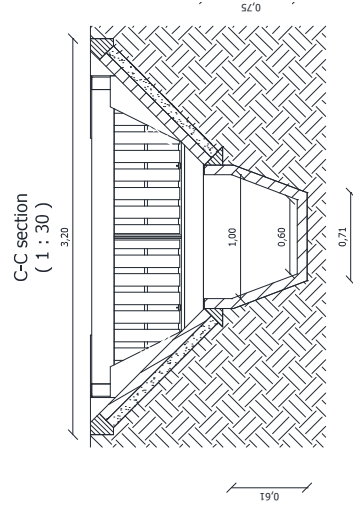
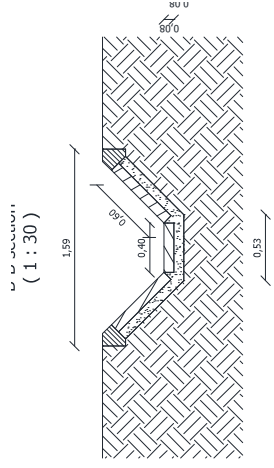

DESIGN AID – ENVIA TRP MULTIPLE UNITS DESIGN

B-B section
(1 : 30)

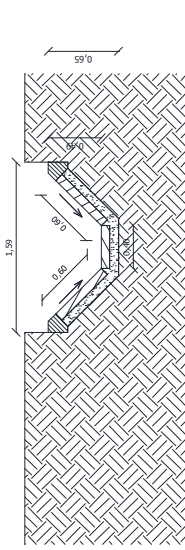

C-C section
(1 : 30)

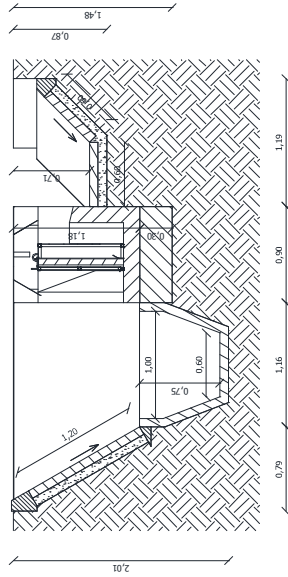

A-A section
(1 : 30)

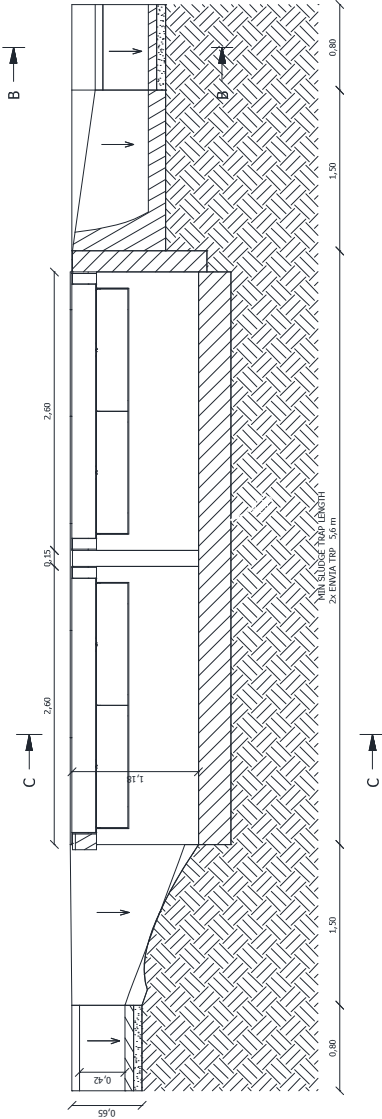

Top View
(1 : 30)

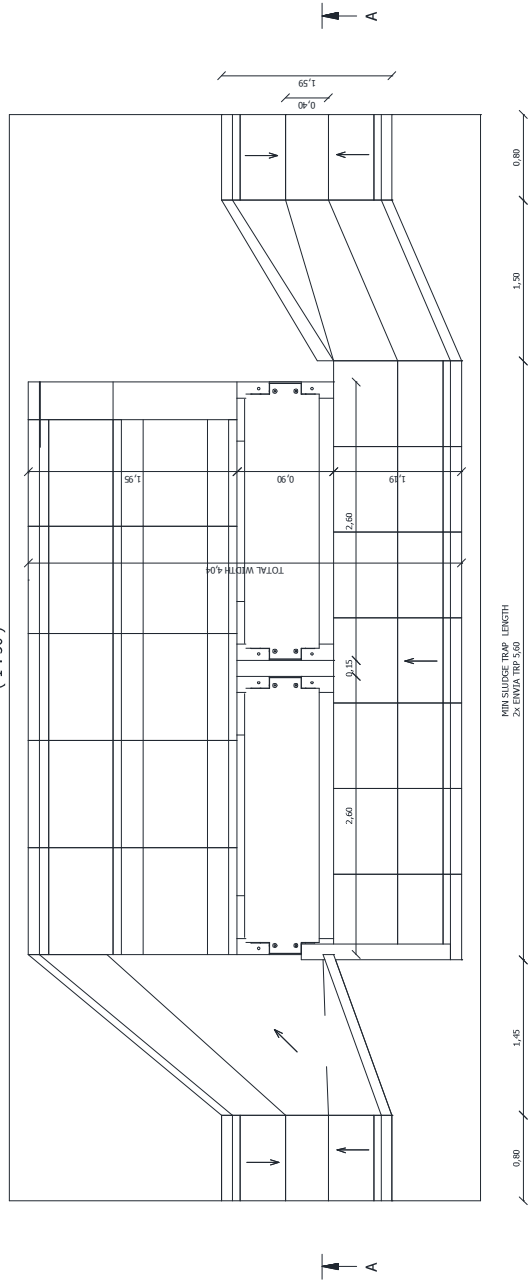

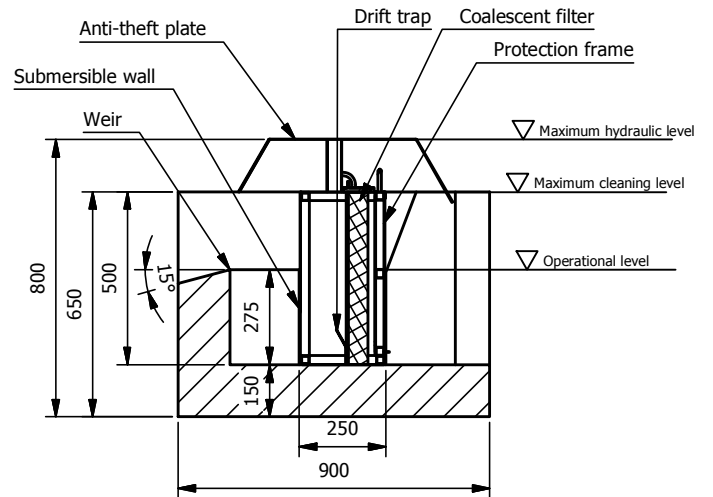
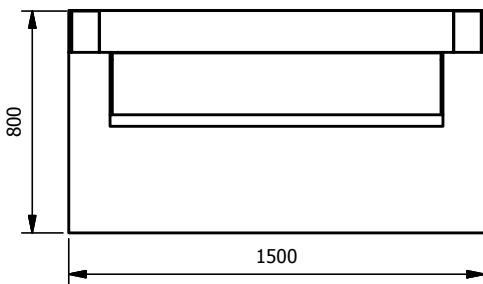
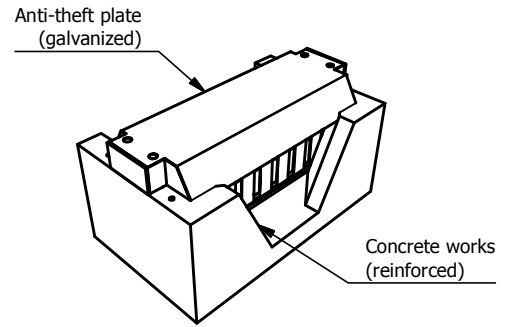
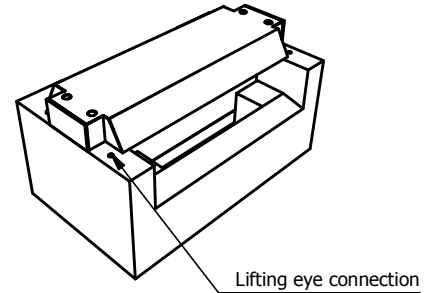
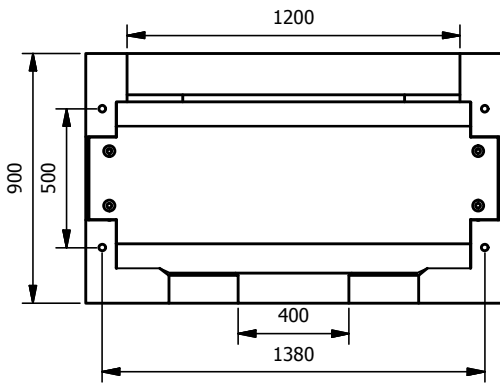
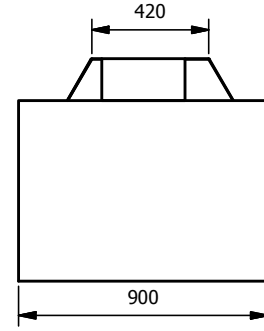
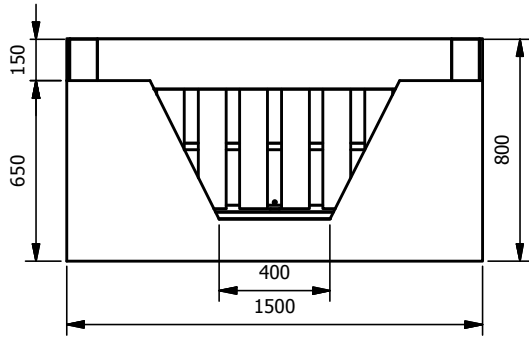

www.pureco.hu

ENVIA TRP drift-trap and light liquid oil separator in open channel

TYP: ENVIA TRP M1A5N 60/120

Informational drawing

M= 1:25

Cleaning capacity:	60	l/s
Total flow:	120	l/s
Efficiency:	5	mg/l FOG
Total weight:	1262	kg

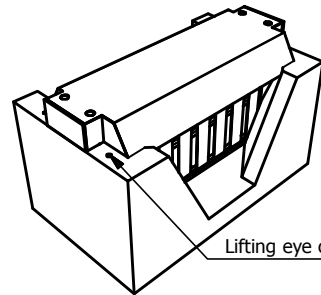
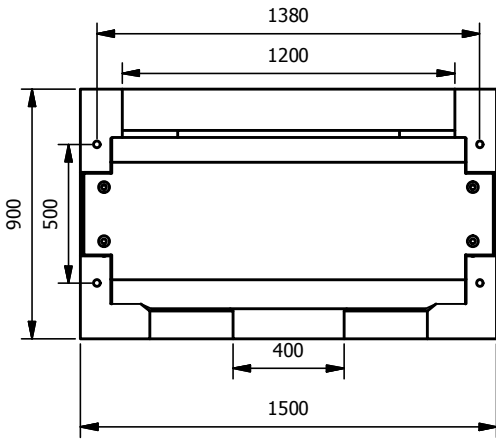
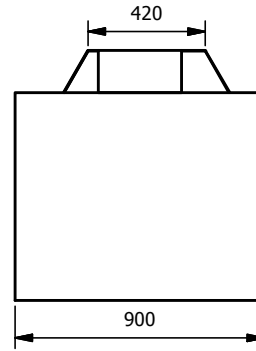
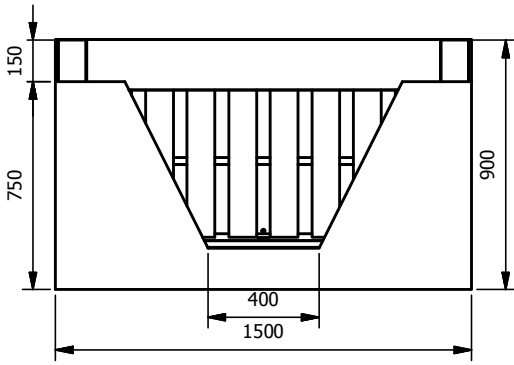

Lifting eye connection

Anti-theft plate (galvanized)

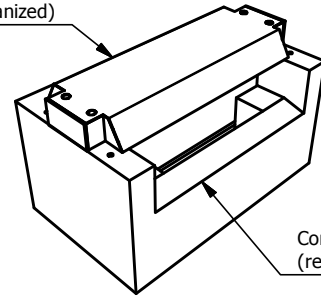

Concrete works (reinforced)

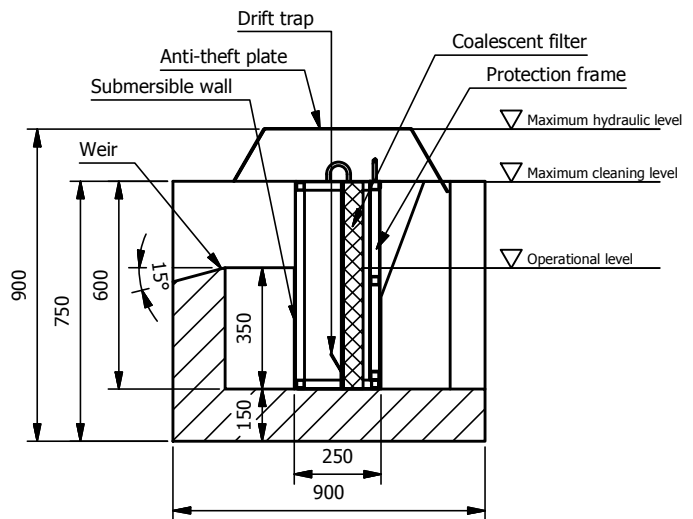
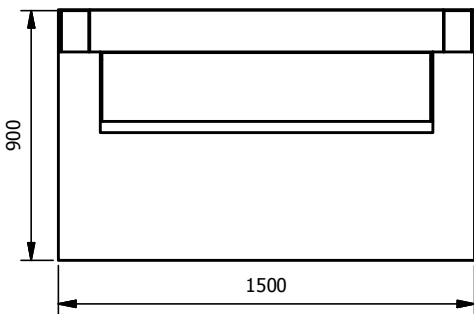

ENVIA TRP drift-trap and light liquid oil separator in open channel

TYP: **ENVIA TRP M1B5N 75/150**

Informational drawing

M= 1:25

Cleaning capacity: 75 l/s

Total flow: 150 l/s

Efficiency: 5 mg/l FOG

Total weight: 1397 kg

www.pureco.hu

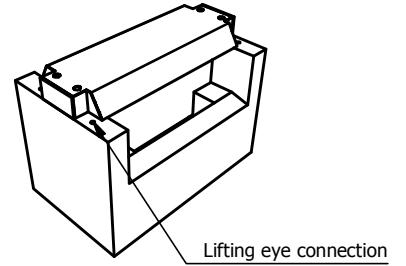
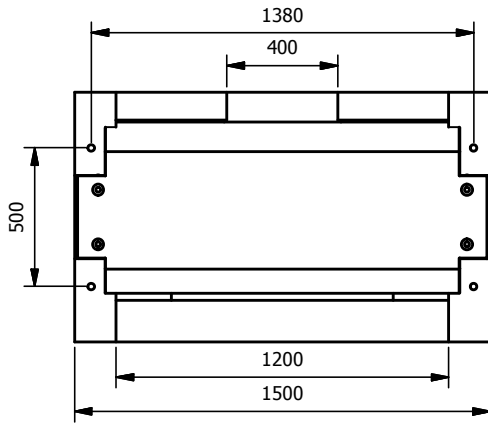
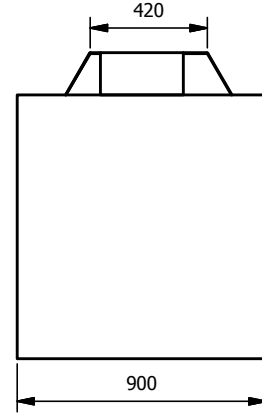
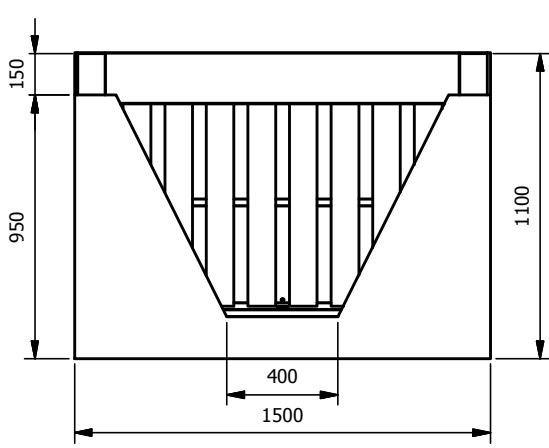

Anti-theft plate (galvanized)

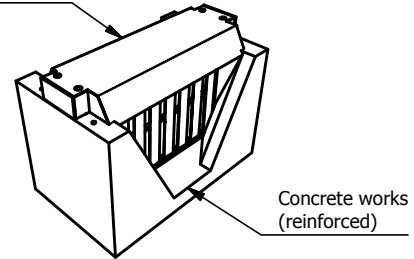

Concrete works (reinforced)

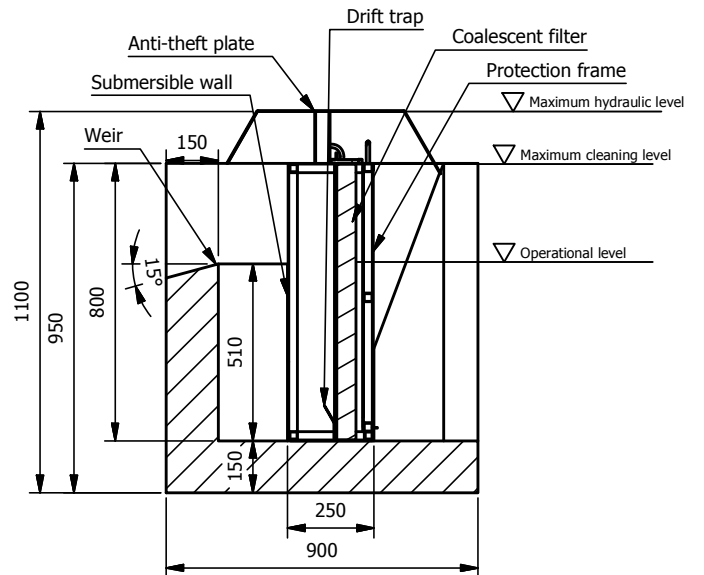
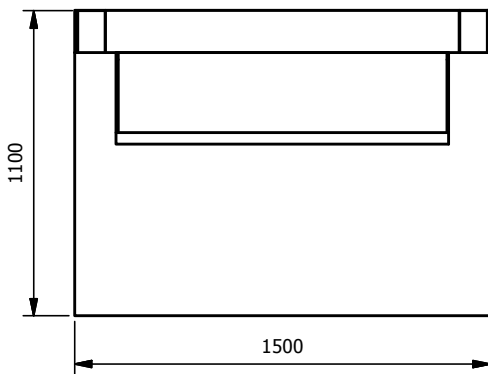

ENVIA TRP drift-trap and light liquid oil separator in open channel

TYP: **ENVIA TRP M1C5N 90/180**

Informational drawing

Cleaning capacity:	90	l/s
Total flow:	180	l/s
Efficiency:	5	mg/l FOG
Total weight:	1660	kg

M = 1:25

www.pureco.hu

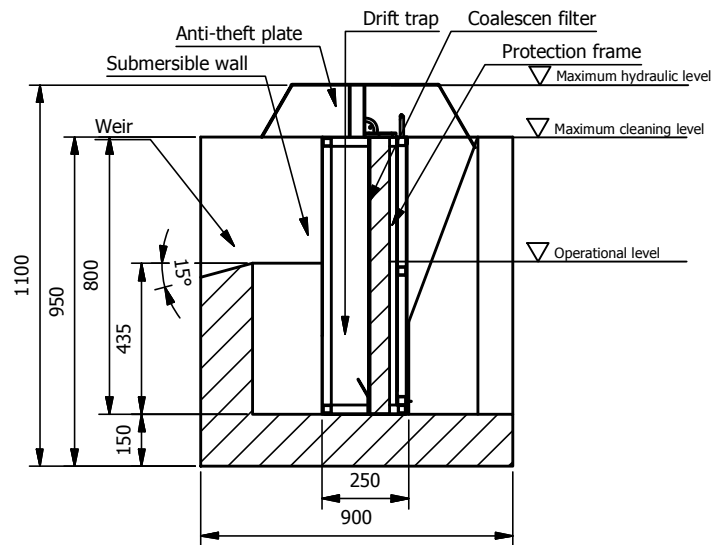
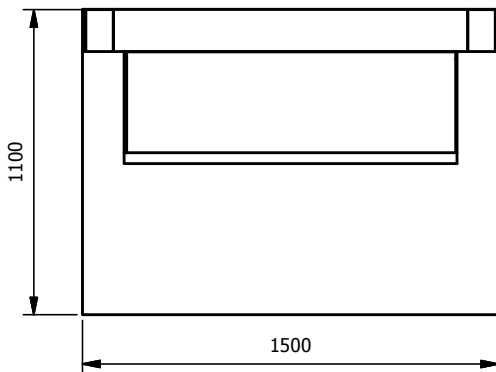
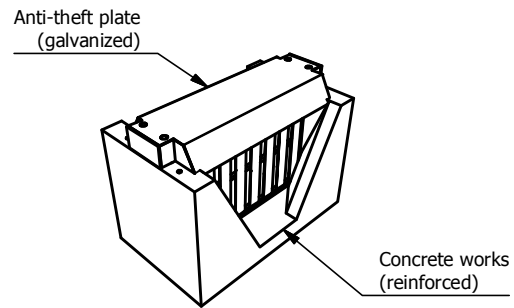
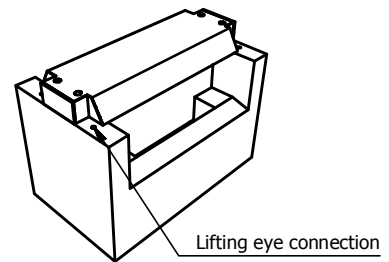
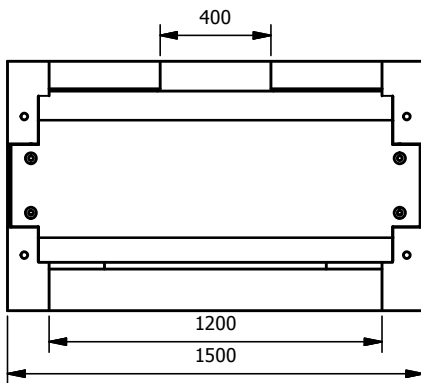
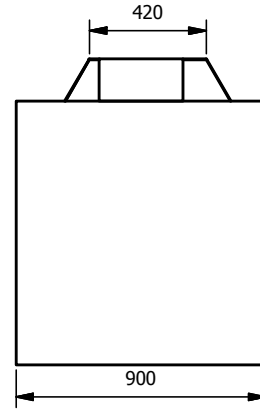
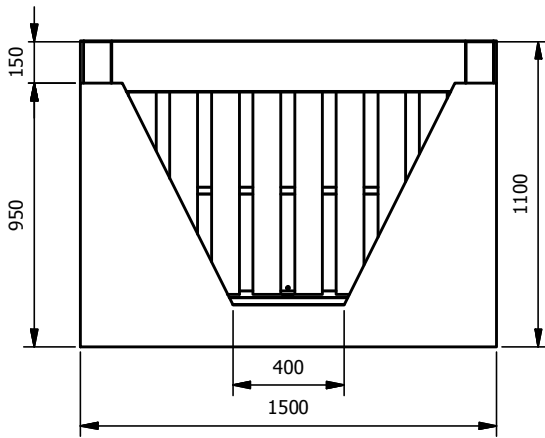

ENVIA TRP drift-trap and light liquid oil separator in open channel

TYP: **ENVIA TRP M1D5N 100/200**

Informational drawing

M= 1:25

Cleaning capacity:	100	l/s
Total flow:	200	l/s
Efficiency:	5	mg/l FOG
Total weight:	1610	kg

www.pureco.hu

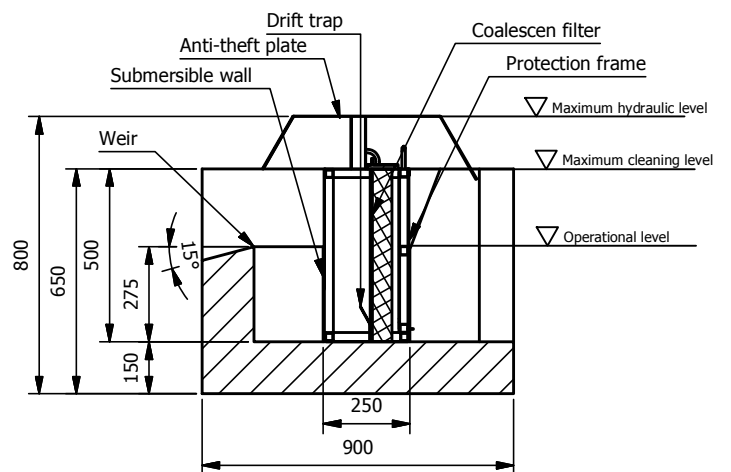
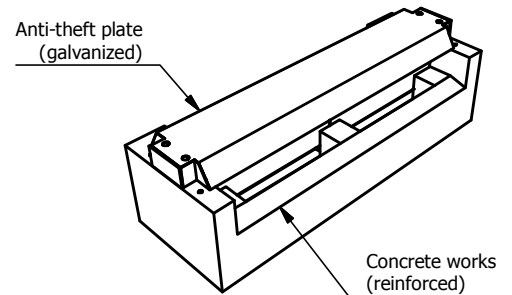
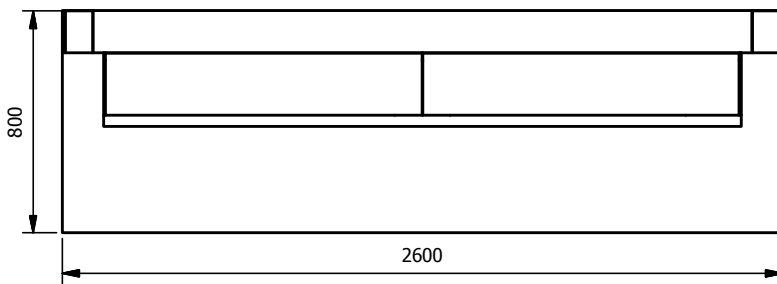
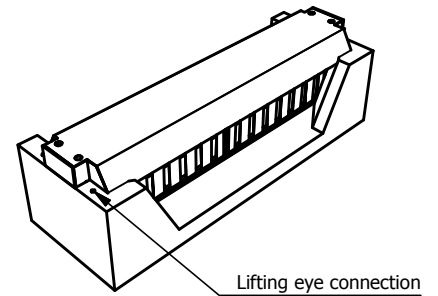
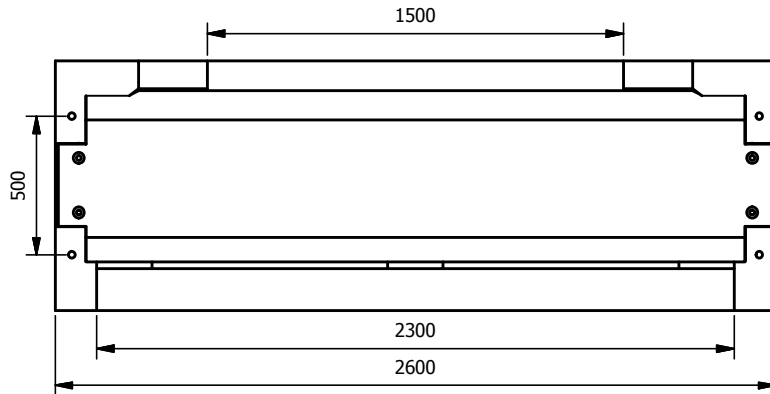
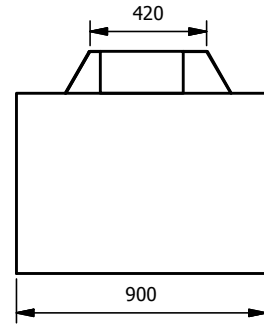
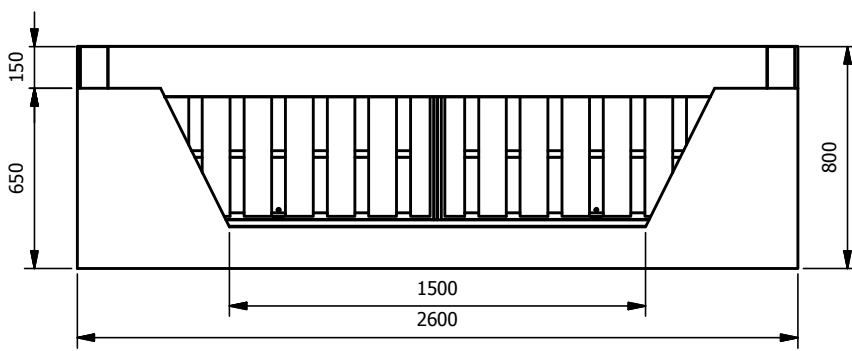

ENVIA TRP drift-trap and light liquid oil separator in open channel

TYP: **ENVIA TRP D1A5N 125/250**

Informational drawing

Cleaning capacity:	125	l/s
Total flow:	250	l/s
Efficiency:	5	mg/l FOG
Total weight:	1832	kg

M = 1:25

www.pureco.hu

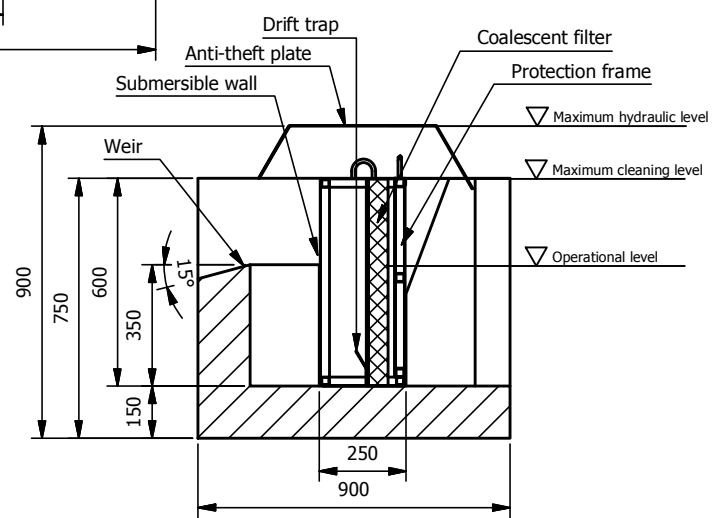
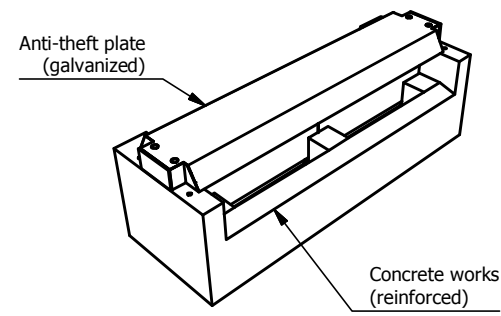
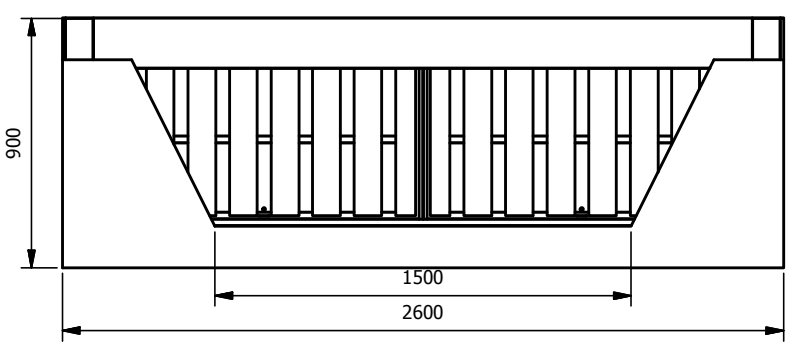
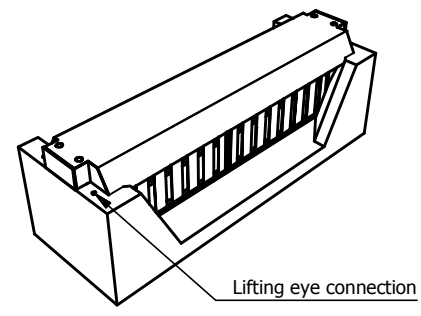
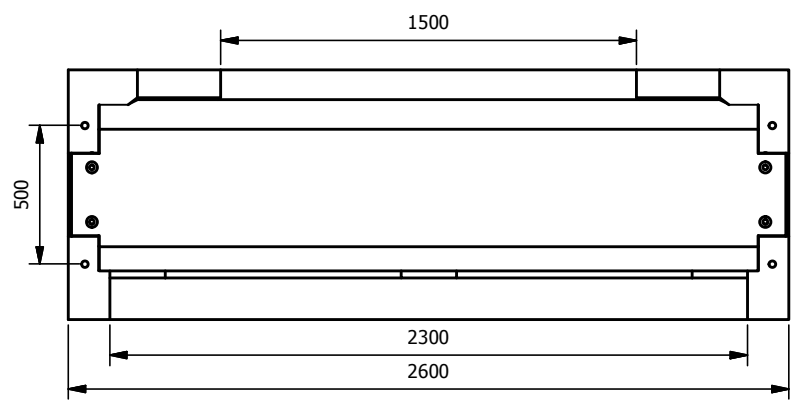
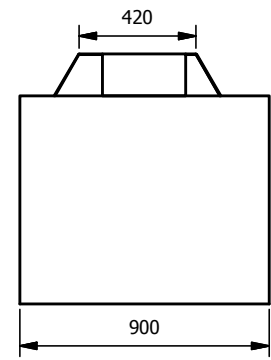
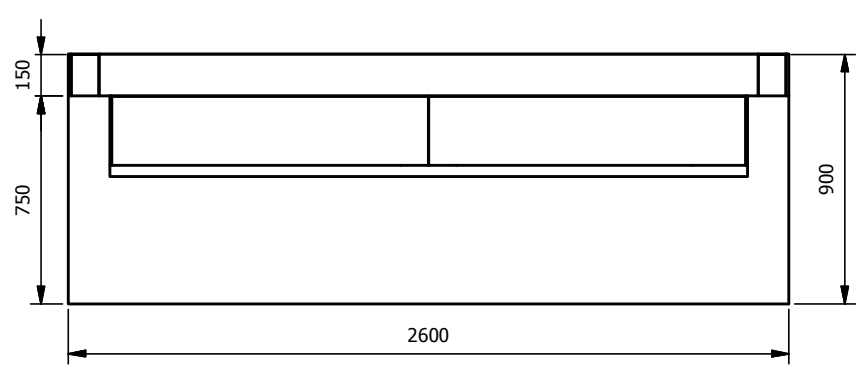

Cleaning capacity:	150	l/s
Total flow:	300	l/s
Efficiency:	5	mg/l FOG
Total weight:	2011	kg

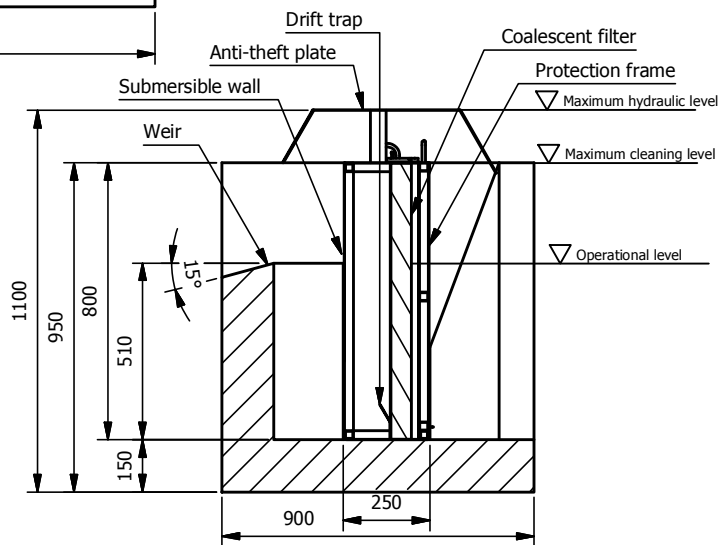
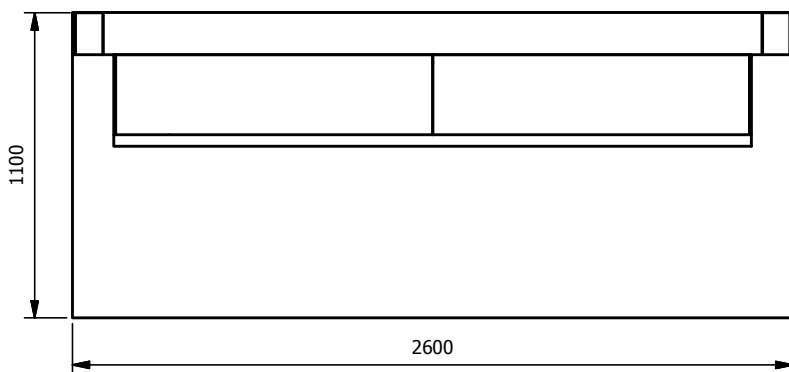
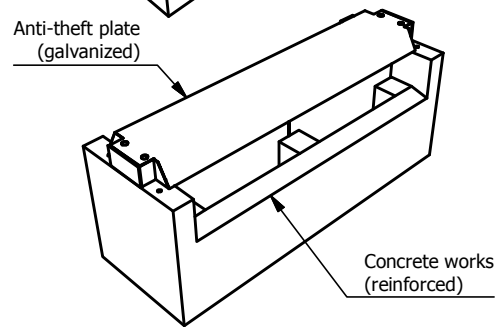
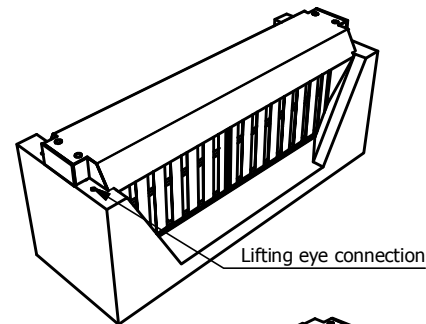
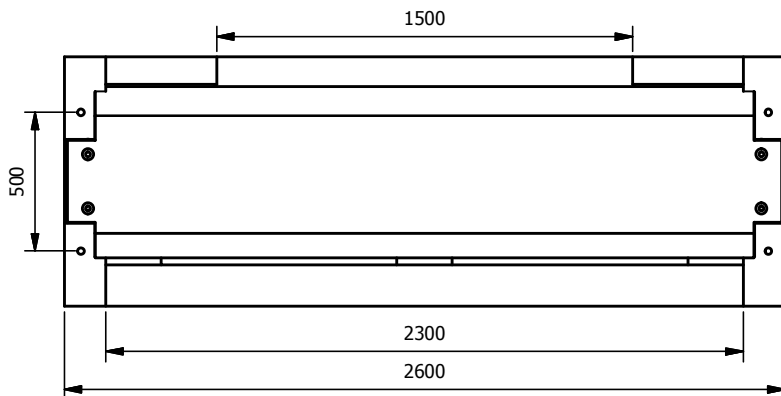
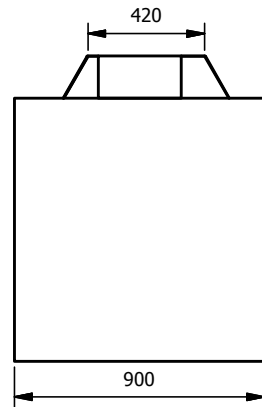
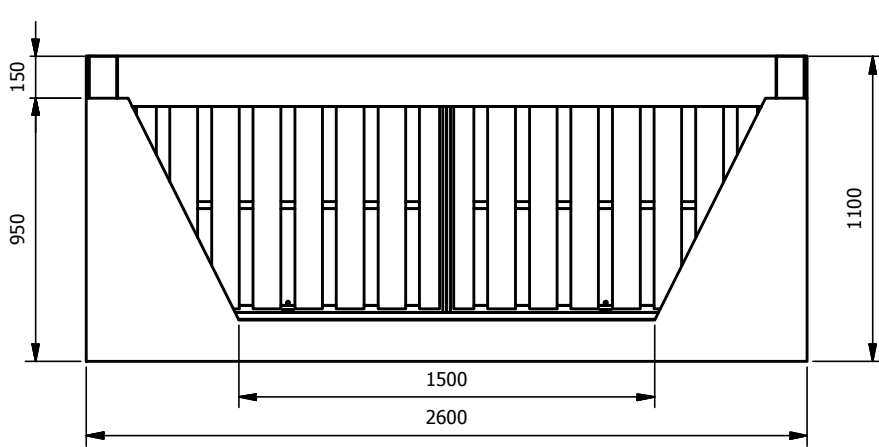

ENVIA TRP drift-trap and light liquid oil separator in open channel

TYP: ENVIA TRP D1C5N 200/350

Informational drawing

Cleaning capacity:	200	l/s
Total flow:	350	l/s
Efficiency:	5	mg/l FOG
Total weight:	2011	kg

M= 1:25

www.pureco.hu

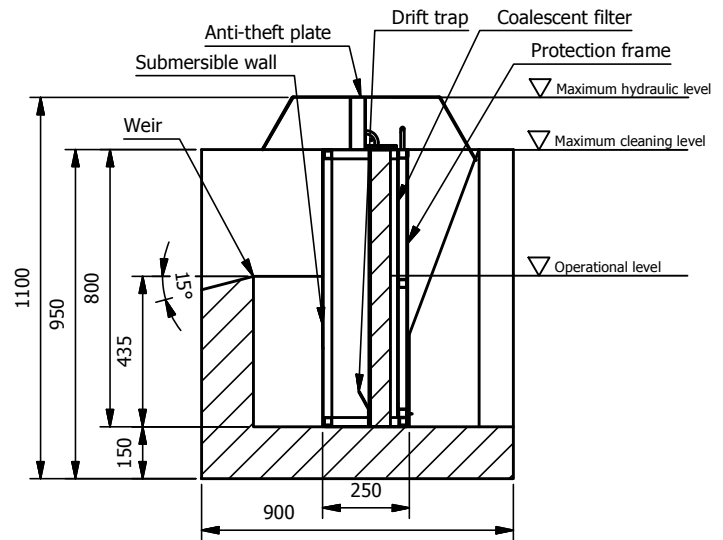
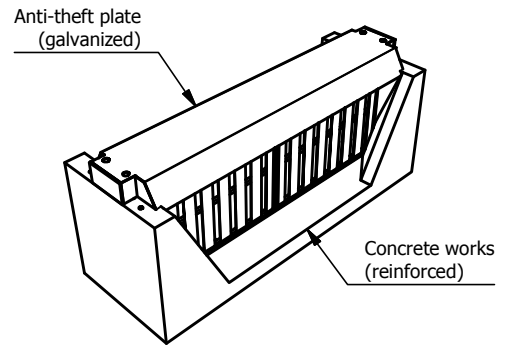
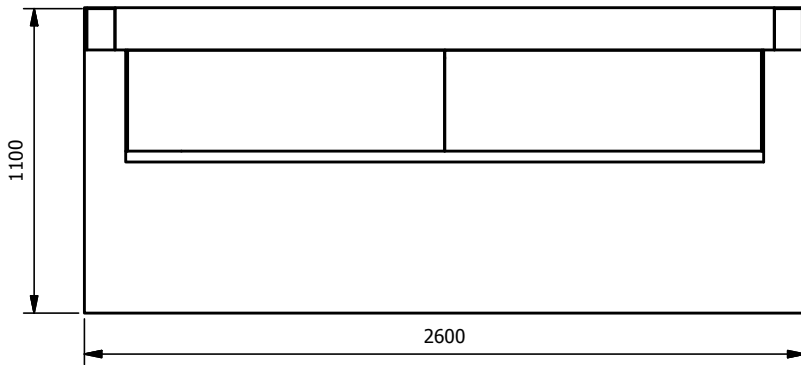
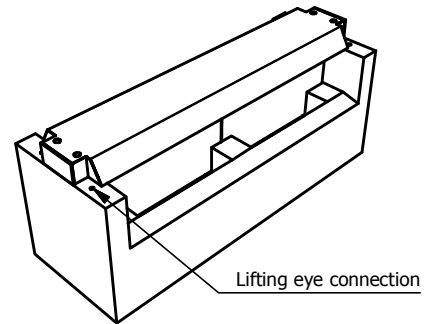
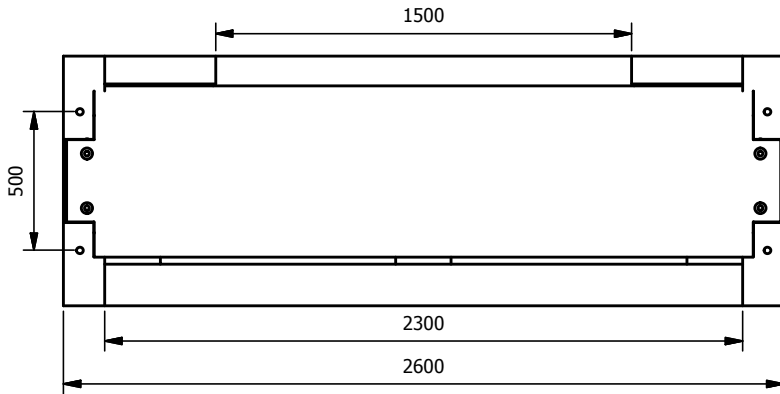
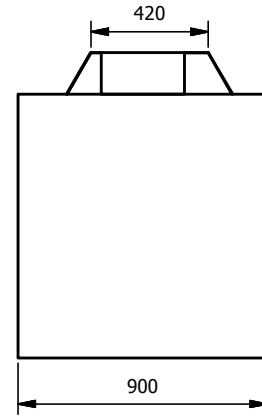
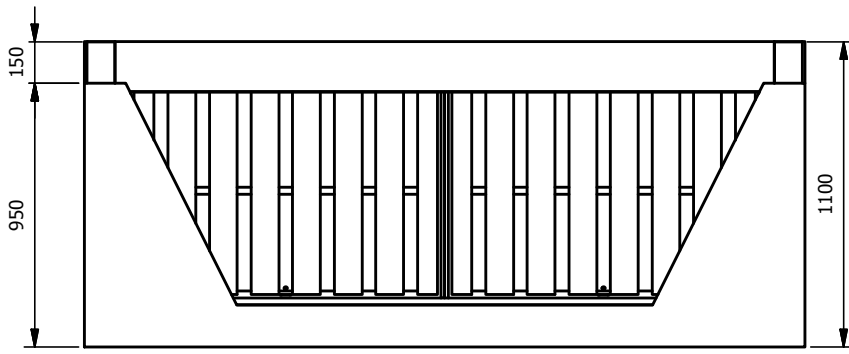

www.pureco.hu

ENVIA TRP drift-trap and light liquid oil separator in open channel

TYP: ENVIA TRP D1D5N 225/400

Informational drawing

M= 1:25

Cleaning capacity:	225	l/s
Total flow:	400	l/s
Efficiency:	5	mg/l FOG
Total weight:	2277	kg

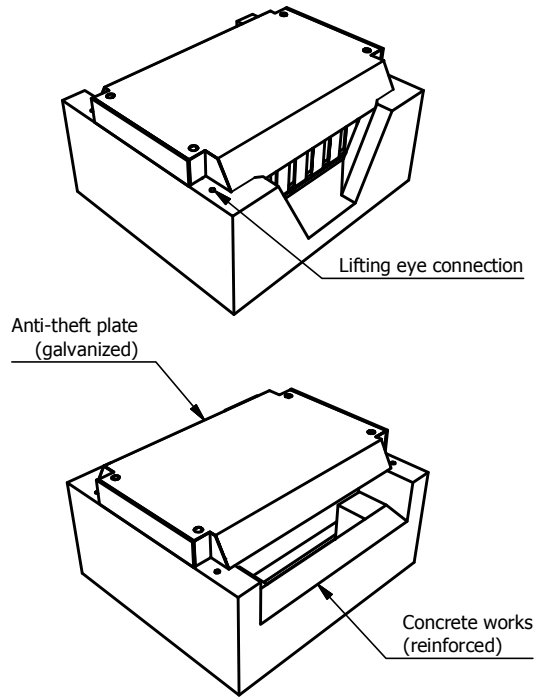
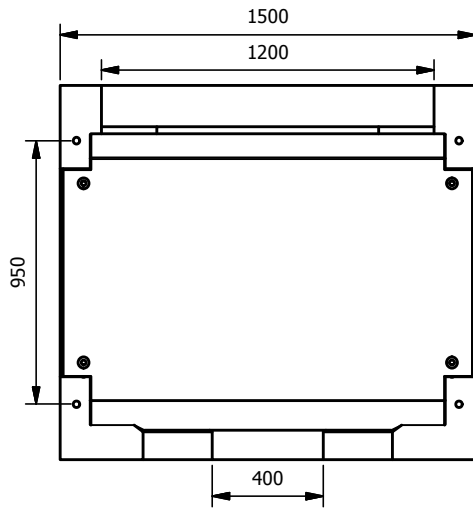
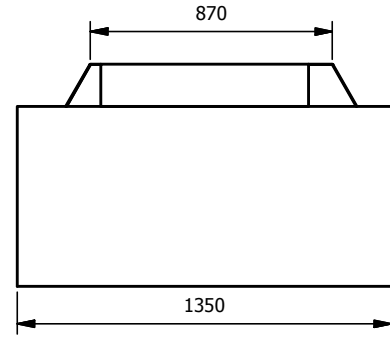
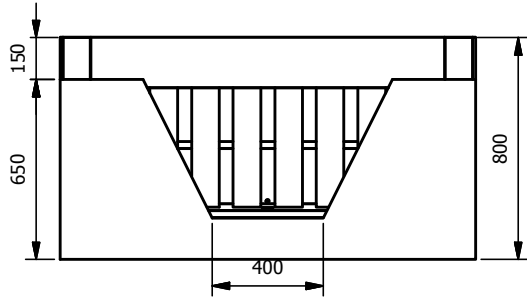

A

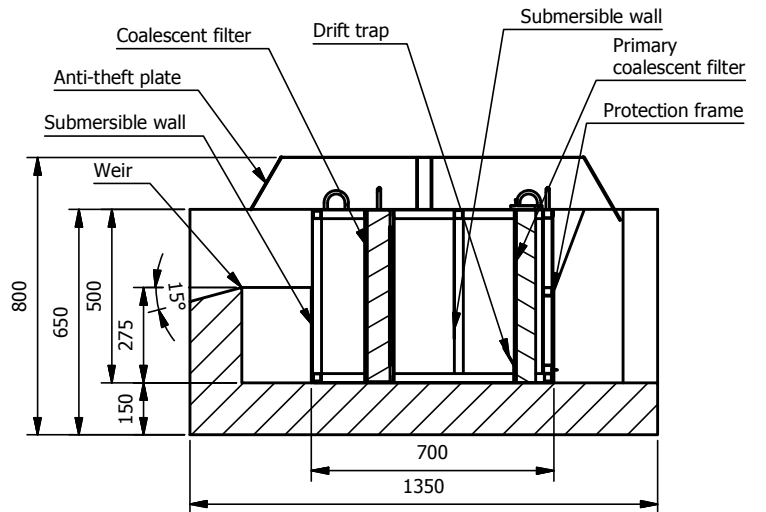
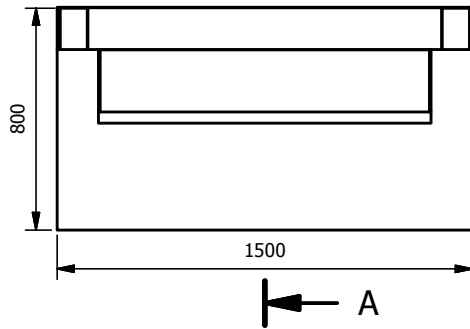

ENVIA TRP drift-trap and light liquid oil separator in open channel

TYP: ENVIA TRP M2A2N 40/80

Informational drawing

Cleaning capacity:	40	l/s
Total flow:	80	l/s
Efficiency:	2	mg/l FOG
Total weight:	1710	kg

M= 1:25

www.pureco.hu

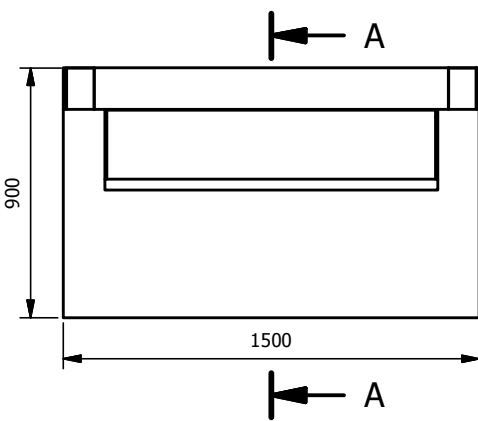
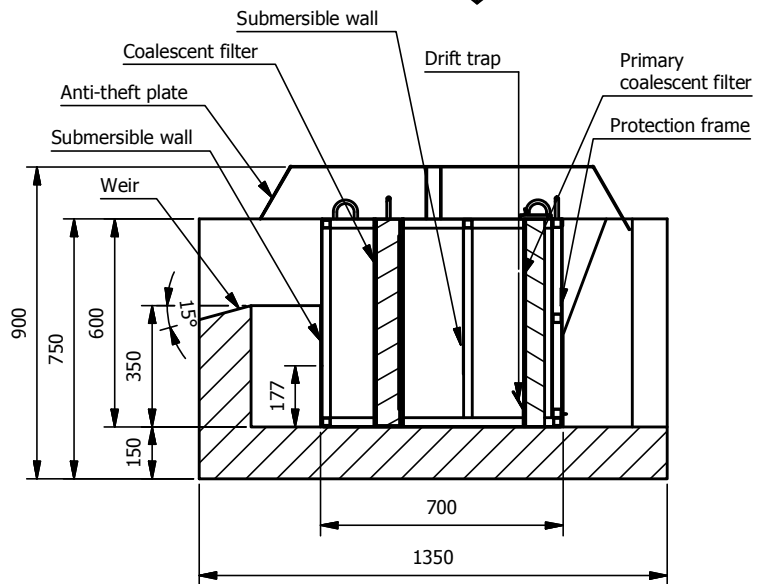
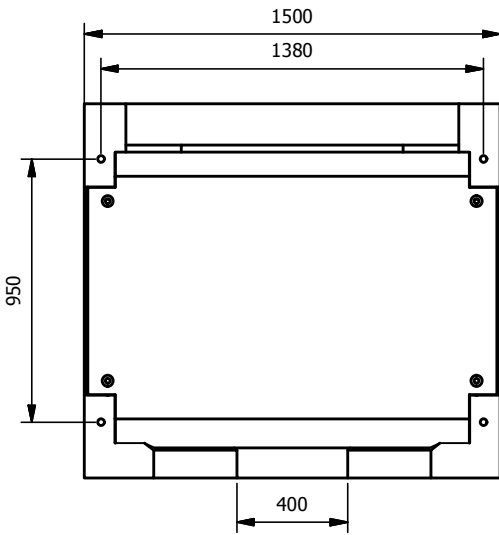
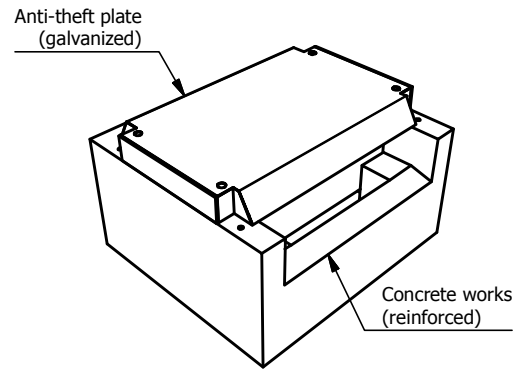
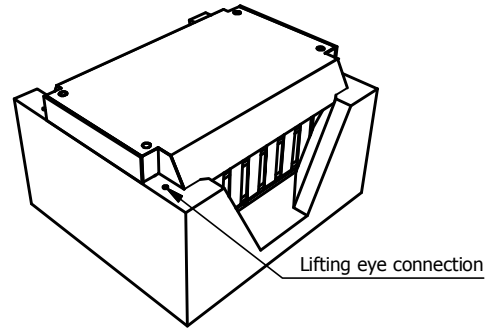
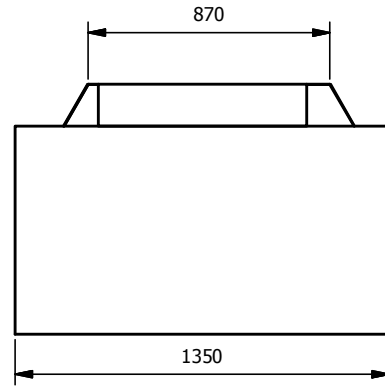
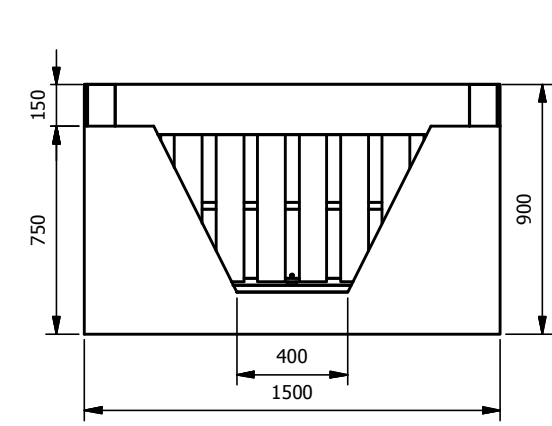

www.pureco.hu

ENVIA TRP drift-trap and light liquid oil separator in open channel

TYP: **ENVIA TRP M2B2N 55/110**

Informational drawing

M= 1:25

Cleaning capacity:	55	l/s
Total flow:	110	l/s
Efficiency:	2	mg/l FOG
Total weight:	1924	kg

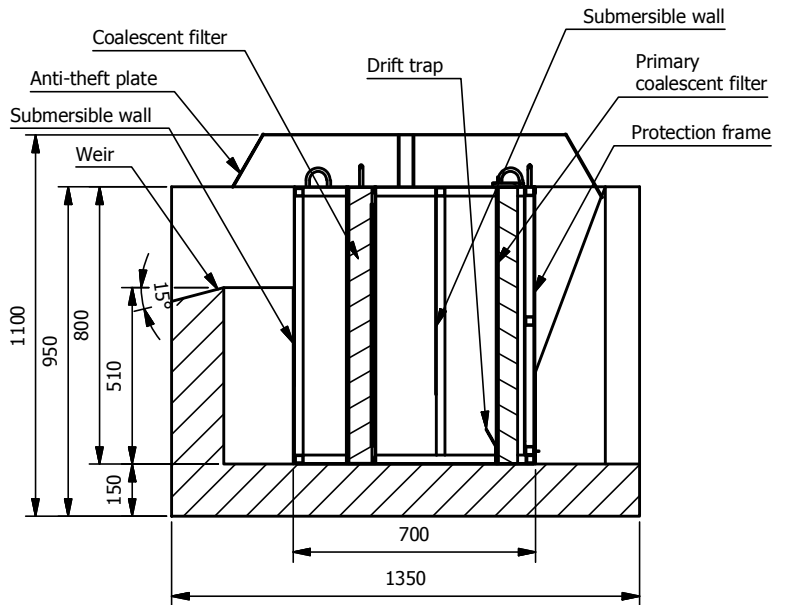
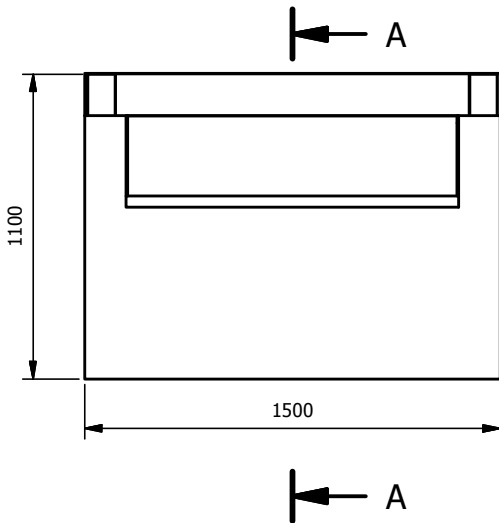
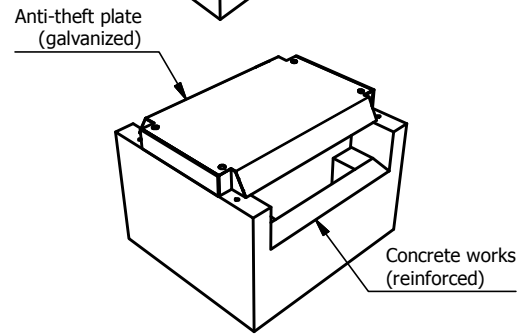
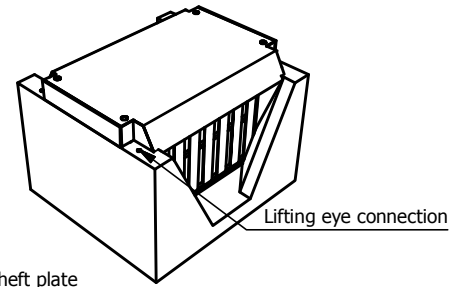
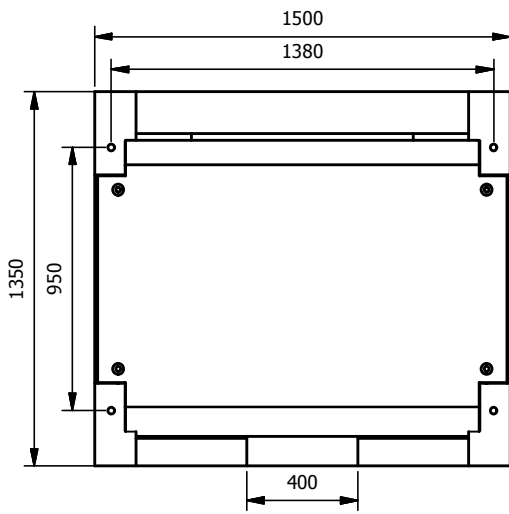
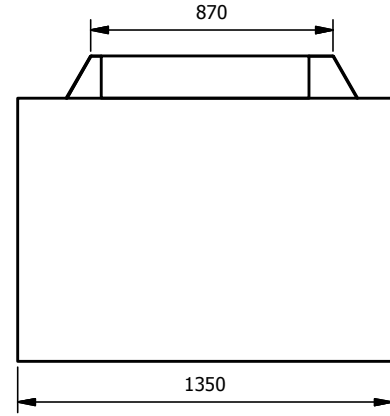
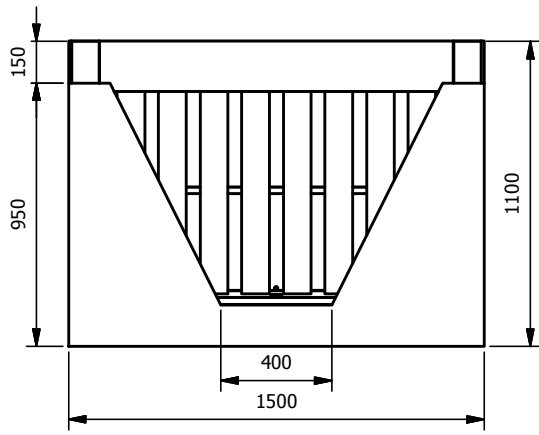

ENVIA TRP drift-trap and light liquid oil separator in open channel

TYP: ENVIA TRPM2C2N 75/150

Informational drawing

Cleaning capacity:	75	l/s
Total flow:	150	l/s
Efficiency:	2	mg/l FOG
Total weight:	2265	kg

M = 1:25

www.pureco.hu

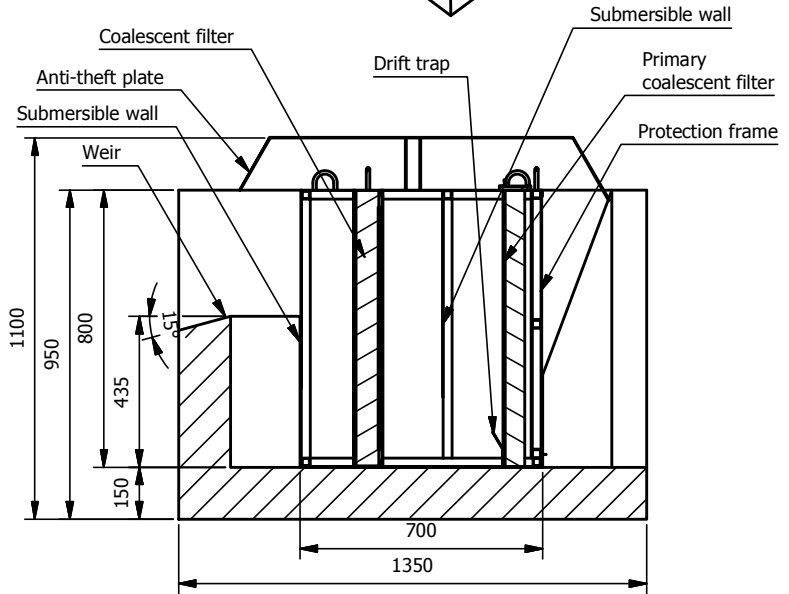
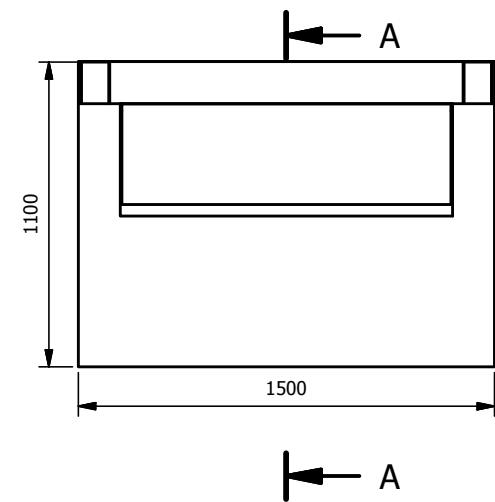
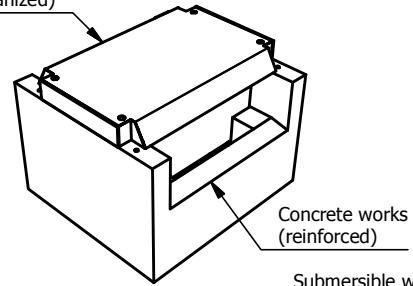
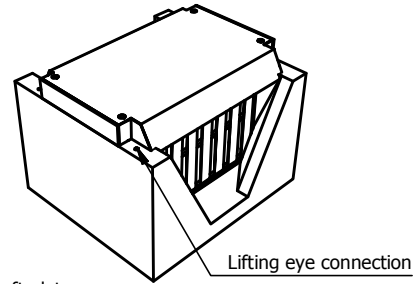
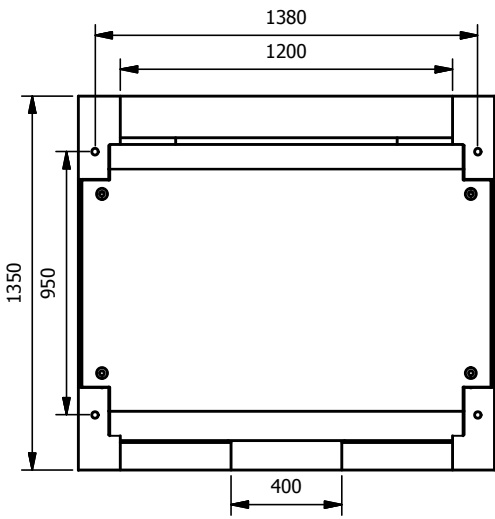
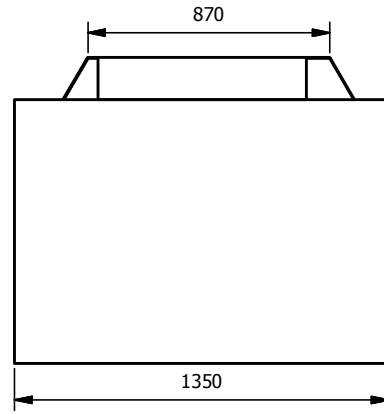
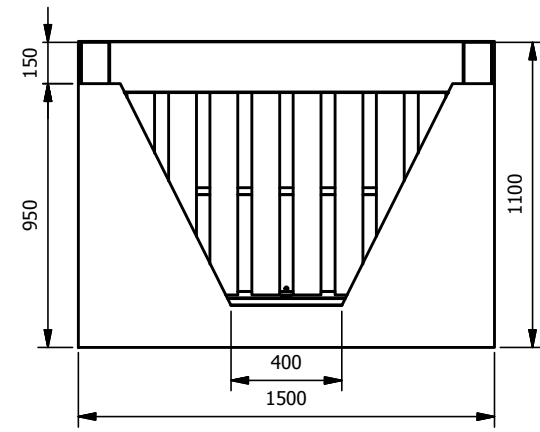

www.pureco.hu

ENVIA TRP drift-trap and light liquid oil separator in open channel

TYP: **ENVIA TRP M2D2N 85/170**

Informational drawing

M= 1:25

Cleaning capacity:	85	l/s
Total flow:	170	l/s
Efficiency:	2	mg/l FOG
Total weight:	2214	kg

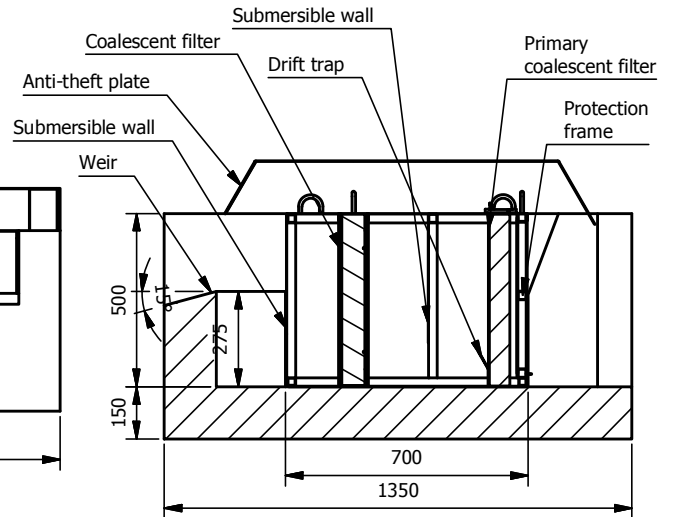
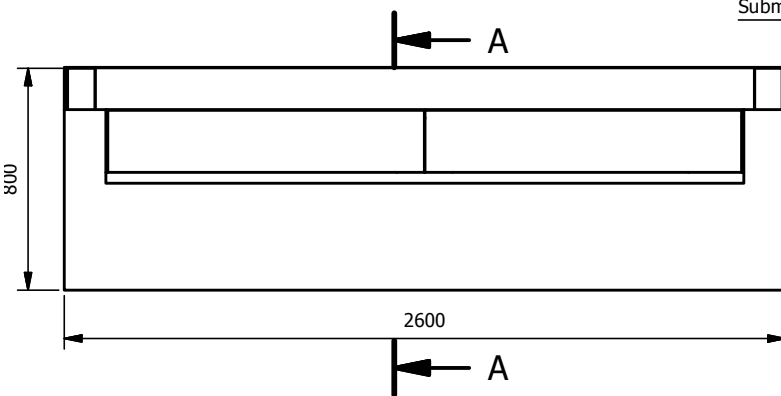
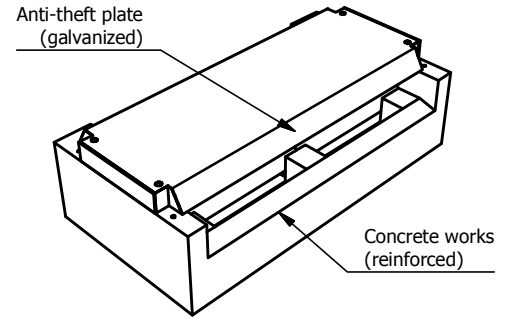
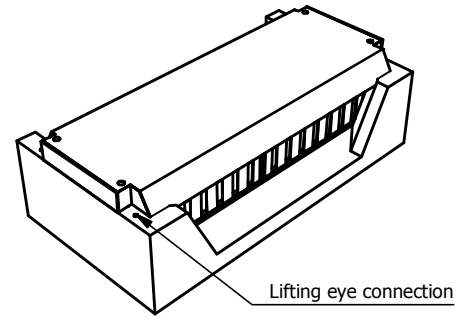
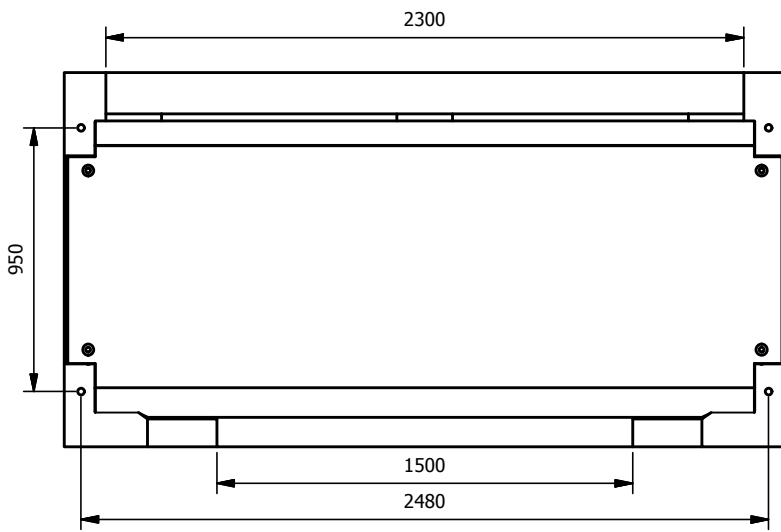
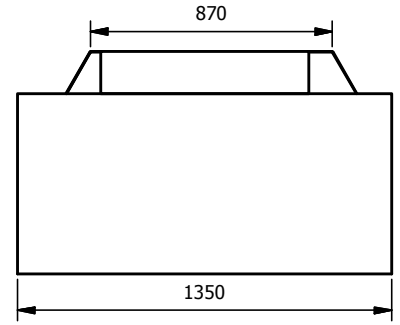
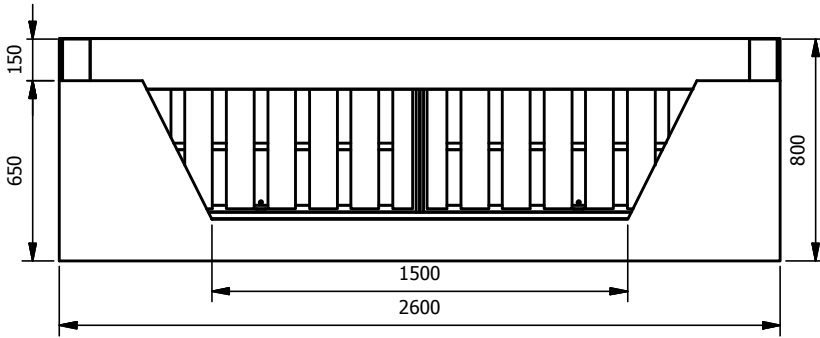

ENVIA TRP drift-trap and light liquid oil separator in open channel

TYP: ENVIA TRP D2A2N 100/200

Informational drawing

Cleaning capacity:	100	l/s
Total flow:	200	l/s
Efficiency:	2	mg/l FOG
Total weight:	2554	kg

M = 1:25

www.pureco.hu

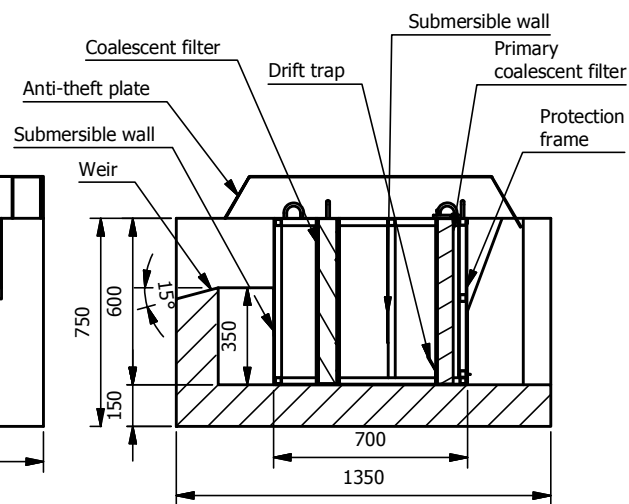
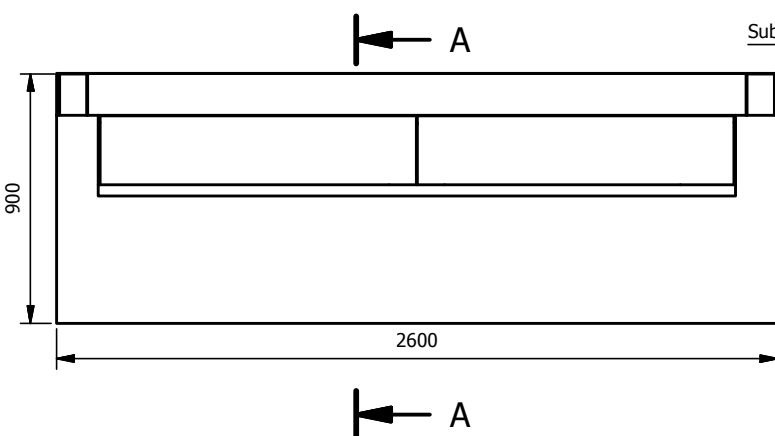
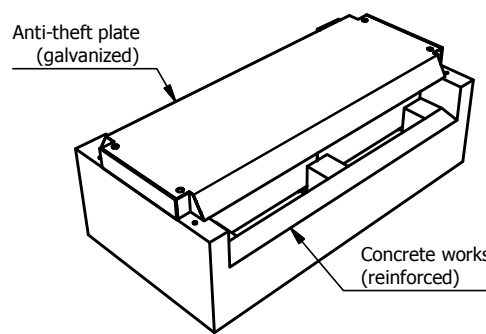
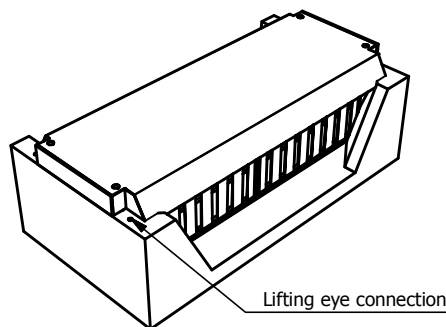
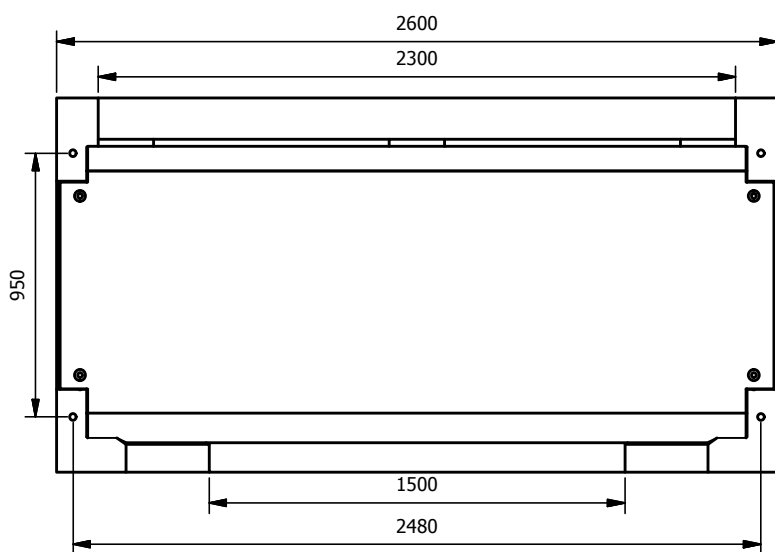
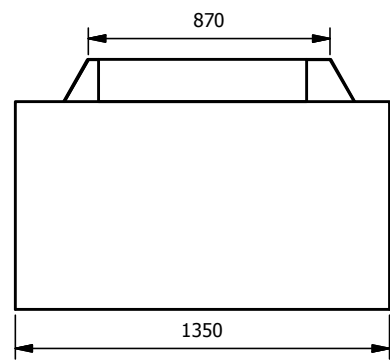
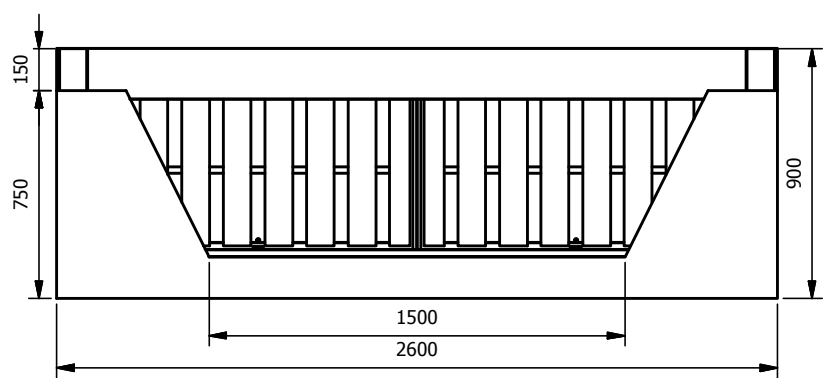

www.pureco.hu

ENVIA TRP drift-trap and light liquid oil separator in open channel

TYP: **ENVIA TRP D2B2N 125/250**

Informational drawing

M= 1:25

Cleaning capacity:	125	l/s
Total flow:	250	l/s
Efficiency:	2	mg/l FOG
Total weight:	2773	kg

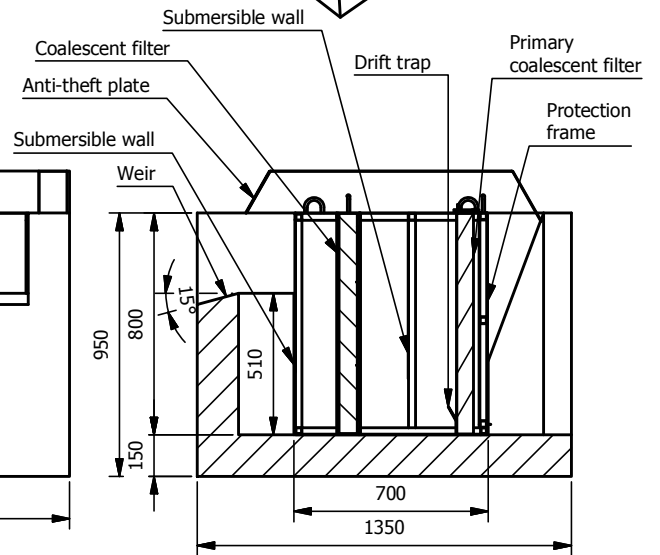
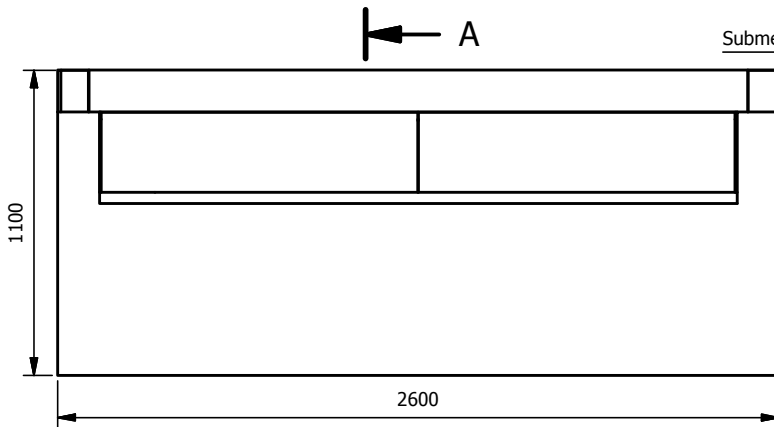
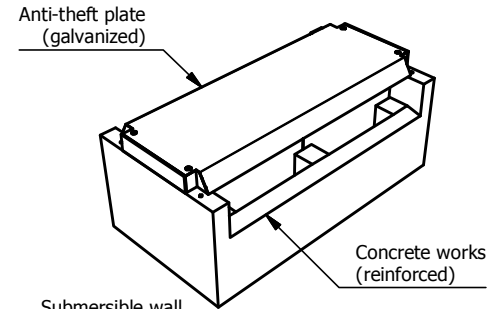
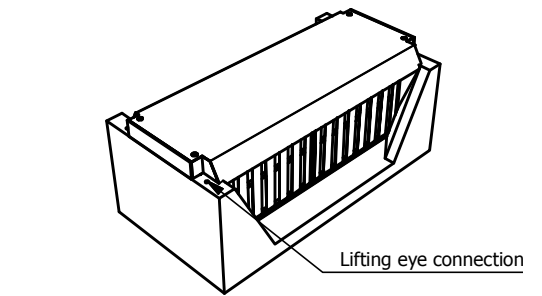
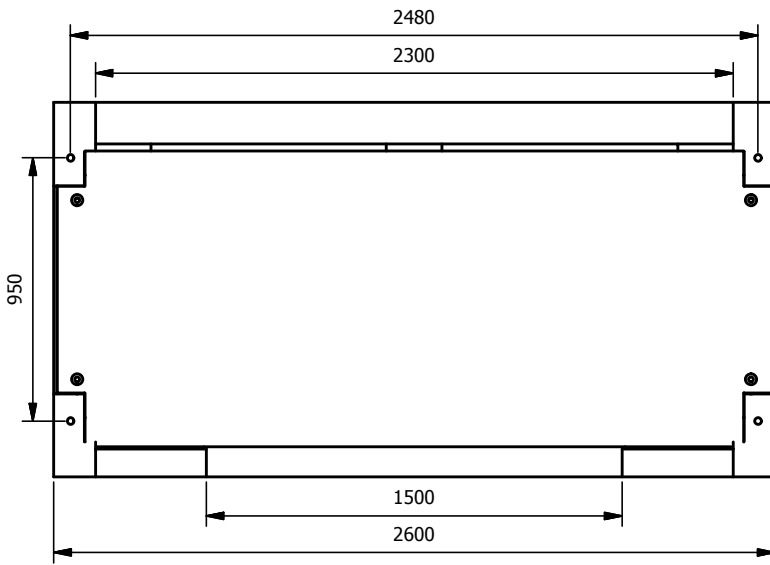
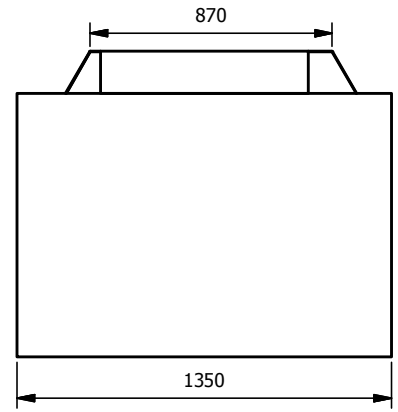
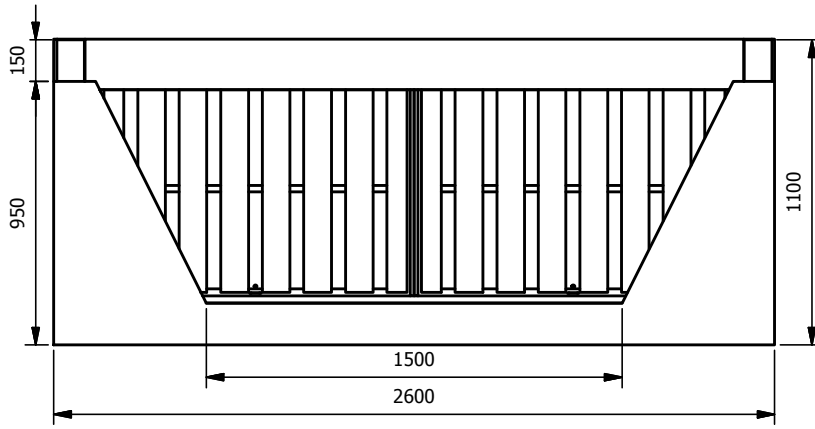

ENVIA TRP drift-trap and light liquid oil separator in open channel

TYP: ENVIA TRP D2C2N 180/320

Informational drawing

Cleaning capacity:	180	l/s
Total flow:	320	l/s
Efficiency:	2	mg/l FOG
Total weight:	3205	kg

www.pureco.hu

M = 1:25

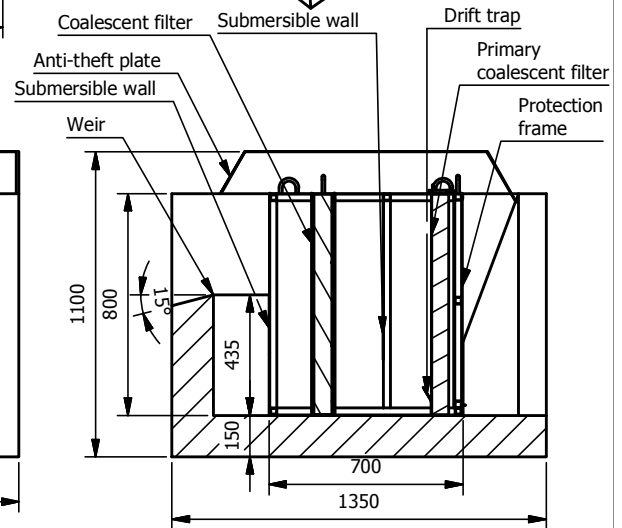
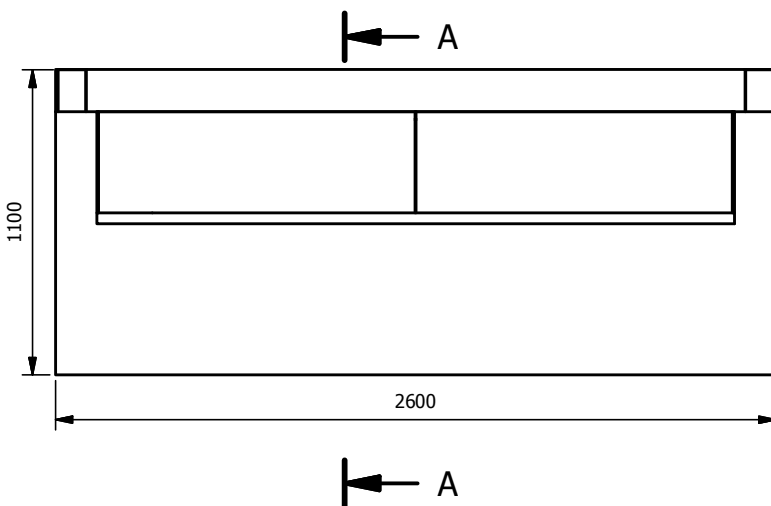
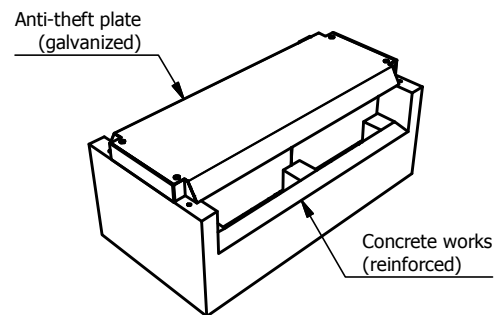
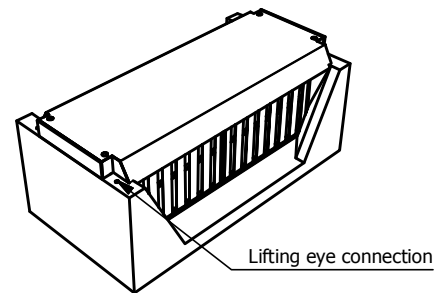
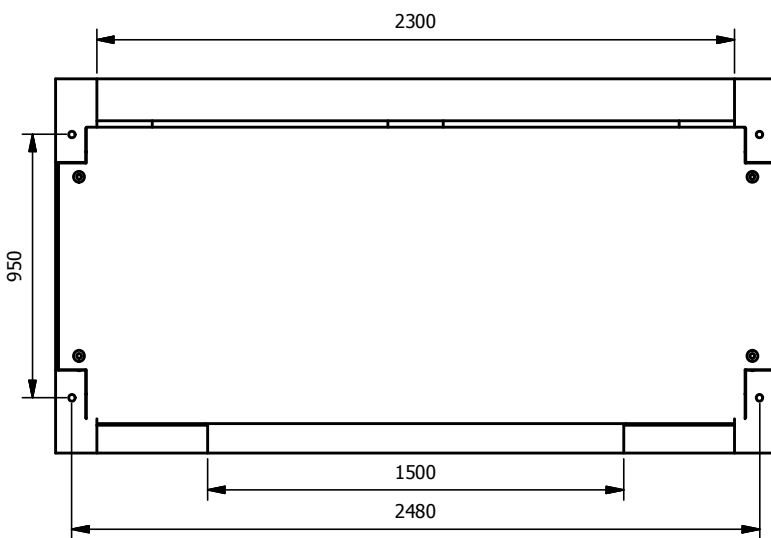
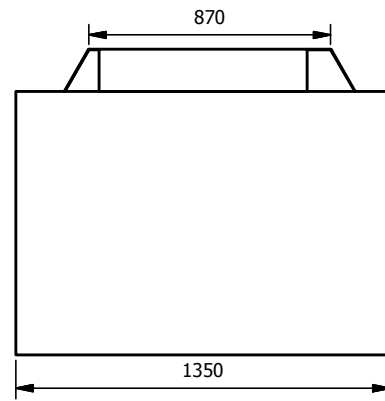
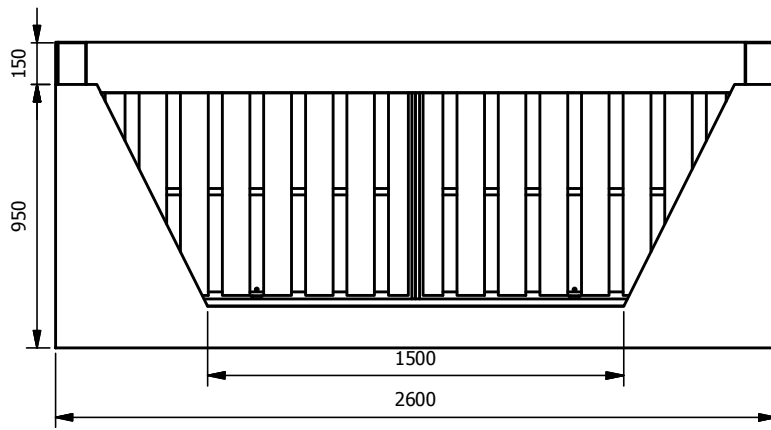

www.pureco.hu

ENVIA TRP drift-trap and light liquid oil separator in open channel

TYP: **ENVIA TRP D2D2N 200/360**

Informational drawing

M= 1:25

Cleaning capacity:	200	l/s
Total flow:	360	l/s
Efficiency:	2	mg/l FOG
Total weight:	3120	kg

GENERAL INSTALLATION INSTRUCTIONS – ENVIA TRP

OIL SEPARATORS

GREASE SEPARATORS

PUMPING STATIONS

INFILTRATION

STORAGE TANKS

1. Work pit (ENVIA® TRP equipment)

A work pit with a square footprint must be made, by a slope or by strutting, depending on soil stability. Taking into consideration the stability and the supporting solutions of the work pit, the purpose is to make the smallest possible work pit necessary for receiving the prefabricated reinforced concrete receiver unit, in order to ensure that the axis of the crane's erection point (king axis) should not be too far from the installation axis, but still it should not jeopardize safe working.

If, according to the soil mechanical expert's opinion, the ground is hard enough, the lower part of the work pit can have vertical sides, and it is enough to make a slope only at the upper part.

The size of the work pit (sole dimensions): the outer contour dimensions of the receiver reinforced concrete unit + about 60 cm at each side to allow for lifting the equipment in, and for compacting.

The construction works of the work pit itself, as well as the works performed inside the work pit must be in compliance with the relevant health and safety provisions.

The points at which the crane supports itself on the ground shall be outside the breaking area around the work pit; if it is not possible, the work pit must be supported; the extra loads must be taken into account when establishing the dimensions of the supports (without anchoring or strutting, the work pit must not be loaded by the crane within the breaking area).

Depth of work pit: the installation depth of the receiver reinforced concrete unit plus the thickness of the layer of the receiver level.

The construction of the receiver level depends also on the soil-mechanical properties of the installation site; care must be taken to make proper foundation, taking into consideration the water pressure swelling in front of the equipment.

The receiver reinforced concrete unit sits onto the top of a concrete wall that closes down the drift-trap box being in front of the equipment, therefore the closing wall must be made to be able to bear loads to the required depth.

It is not allowed to place the receiver reinforced concrete unit directly into the work pit (onto the natural soil); if the work pit is excavated before the installation works take place, it must be covered if possible (to protect it against storm waters); it must be cordoned off in accordance with the specifications, as well as it must be illuminated under special installation circumstances (busy traffic).

The work pit must be protected against spontaneous waters coming from the upstream side during construction; such waters must be led away by-passing the work pit.

Should the completed soling get contaminated (falling earth, slurry, snow, etc.), it must be cleaned before the receiver reinforced concrete units are installed to avoid unwanted sinking in the future.

If it is necessary to remove water, we recommend the following method (if the water removal is possible through open water keeping): an enlarged work pit with a sump necessary for pumping.

In the case of open water keeping, care must be taken continuously to avoid hydraulic soil breakages, with special view to dynamic exposures during crane-use.

When the soil is susceptible to collapsing or breaking, either a closed row of planks or a sheet wall piling must be applied for strutting the work pit. When the groundwater level is too high, or when an open water keeping is not applicable, the water must be removed from the soil by vacuum wells.

2. Putting the equipment to its place (ENVIA® TRP equipment)

- The prefabricated reinforced concrete receiver unit should be placed into the work pit by a crane, which should be selected by taking into consideration the place of the crane's sole, the weight of the unit to be lifted, and the required load-bearing capacity.
- A table can be used for selecting the best crane, however the best solution is to survey the site in advance.
- The ground conditions necessary to support the crane properly must be ensured.
- Access to the work pit must be provided through the construction of a road with the required load-bearing capacity, taking into consideration also the fact that the reinforced concrete units are transported by lorries used normally on public roads.
- If the employer assigns the task of transportation to the manufacturer, self-loading vehicles will be used in that case (also for smaller equipment, so the transport vehicle must be able to stand directly near the work pit). (This must be settled in advance in each case, otherwise the manufacturer/deliverer should not be obliged to lift the pieces into the work pit!).
- A rope with the required load-bearing capacity should be used for placing the reinforced concrete receiver unit into the work pit. The hoisting rope should be connected to a balance. It is forbidden to use the rope for lifting when it is in a vertex angle! In opposite cases the cover plate and/or the spacer fixed by adhesive to its side (that makes proper installation possible) may get deformed or damaged.
- The „monocules“ or the hoisting hooks must be hooked into the four RD24 hoisting loops that are screwed into the LOWER hoisting sockets until collision; (the hoisting pin – Dübel - is installed in the side of the reinforced concrete unit)
- Upon specific order, the supplier provides a set (4 pcs) of hoisting loops for the installation, which is invoiced to the customer; if several units are installed, these loops are reusable: they should be removed from the already installed reinforced concrete unit, and they can be

used for the next one too. If the customer returns the hoisting loops in proper condition after the installation is complete, the supplier will repay 75% of the price it invoiced for the hoisting loops.

- If the ropes are used without a hoisting balance, there is a risk that the receiver reinforced concrete unit and the cover plate break in; the manufacturer refuses to undertake responsibility for damages or accidents caused by such practice.
- The inlet and the outlet side of the reinforced concrete receiver unit is marked accordingly, which should be taken into consideration for its installation. The flow bottom level must be checked before the unit is lifted in, and it must be adjusted to the height of adjacent ditch sections and/or the drift-trap box.
- The reinforced concrete receiver unit and any possibly installed mechanical units must be checked for damages; if damages are found, it must be immediately reported and documented.
- The customer and the constructor shall be obliged to make a statement on the condition of received equipment, when its delivery (handover) takes place
- It is practicable to put the reinforced concrete receiver unit to its place by hoisting to the properly prepared receiver floor in such a way that the contours or at least its axis and corner points are marked in advance on the receiver floor.
- It is forbidden to go down to the work pit before the structure hangs only by 20 to 30 cm above its place.
- Two persons must perform the accurate positioning of the reinforced concrete receiver unit; during the hoisting operation these two people should turn the units to the right position, within the marked points.
- It is practicable to have a third person who watches and guides the positioning operation; the purpose is to ensure that the axis of the reinforced concrete unit should coincide with the flow axis.
- If the equipment is installed in such a phase of the construction works, when there is a danger that the process equipment gets damaged or overloaded (mud washed in from the refilled earth), we recommend that the process equipment should be installed later into the receiver reinforced concrete unit; the supplier is ready to carry out these operations, against a fee, when the required conditions are available.
- The reinforced concrete receiver unit should be positioned to be horizontal, being in the same plane with the bottom level of the drainage ditch.

3. Connections

- Efforts should be taken to ensure that the equipment is installed in such a manner that – footprintwise – the axes should fall into the same line (the axis of the inlet channel and of the outlet channel, and that of the structure); in the height perspective: the flow bottom levels should be on the same level.
- The connection between the structure and the ditch section should be made so, that it should prevent the leakage of water and, through that, the collapse of the structure's foundation.

4. Backfilling

- After the receiver reinforced concrete units have been lifted in, and adjusted into their place, then the backfilling works may commence.
- Backfilled earth must be compacted in accordance with the designer's provisions based on the installation circumstances, with special view to possible collapses due to posterior solidification.
- When the covering layer is applied, attention must be paid to possible depressions around the reinforced concrete structure; the installed mechanical systems should not get injured, and earth should not enter the structures (for this reason it is practicable to cover the reinforced concrete unit, and the filter box should be installed in the reinforced concrete unit only after the earth works and pavings have been completed.

5. The construction and pavement of watercourse-beds

In front of the equipment an anterior bottom and a paved ditch section should be constructed, which functions as a settlement area and a storage area during the operations.

In the upstream bed section, a drift-trap „box“ should be constructed either from prefabricated pavement blocks for ditches and watercourse beds, or from a monolithic structure; this box should be installed below the flow bottom level of the ditch, in accordance with the construction drawings and documents.

The water bed must be paved (with bed-paving concrete blocks) inside the swelled upstream area, its length should be at least the length of the drift-trap box, and its height should be the same as the maximum swelled process water level.

The equipment should be concreted (at those sides of the equipment that are in right angles with the flow direction), up to the height of the equipment (including also the cover plate) in such a manner that allows the cover plate to be lifted from the equipment during the

operation; the vertical plane of the on-site concreting should not reach above the structure; it should coincide with the outer plane of the styropor plate glued to the cover plate.

When the water quantity is more than the water flow that belongs to the maximum hydraulic permittivity, excess waters tip over the filter box; for this reason at least one row of bed-pavement concrete blocks should be installed at those sides of the prefabricated reinforced concrete receiver unit, which are parallel with the water flow, in order to protect the slope; on the upstream part: in a length of min. 4 m from the axis of the equipment; on the downstream part: in a length of min. 2 meters.

The narrowed ditch parts, and the backfills (required for the proper installation of the reinforced concrete unit into the ditch section) should also be covered by appropriate paving.

A water-jump occurs on the outlet-side after the weir wall; for this reason the ditch should be paved in at least a 4-m length, up to the height of the maximum swelled process water level.

6. Putting the system into operation

Any contaminating materials that may have entered the structure must be removed in the commissioning process.

Into the cleaned reinforced concrete receiver unit, the filter box (containing the process elements) must be lifted in by a crane in such a manner that the flow-breaker lamellas should face the inlet side.

After the filter(s) are removed, the theft-prevention pins – Dübels - must be installed into the holes that are bored in advance into the side walls of the reinforced concrete unit. Then the filter(s) should be put back to their place.

In the upper part of the side walls of the reinforced concrete receiver unit 4 pins – Dübels - are installed in accordance with the bore holes of the cover plate; the cover plate should be put on its top. Attention! These pins are not suitable for lifting the equipment!

After the theft-preventing cover plate has been put to its place, 4 individually designed bolts must be fixed into these 4 pins by using an individual tool manufactured specifically for this purpose. Attention! This tool must be handed over to the operator in the Handing-over process.

The installed process filter box must be inspected visually. If external injuries are not observed, the equipment is ready to receive water for treatment.

7. Health and safety instructions

The in-detail health, safety, and security provisions pertaining to the time of the construction works must be observed in accordance with the time of the year, the weather, and the installation site, and in accordance with the designer's provisions specified in the design documentation of related works.

Before work is started, the work tools must be checked whether or not they are damaged; Only properly trained personnel should be allowed to perform work, under continuous technical supervision and guidance.

Before the work pit is excavated, information should be collected whether such public utility lines should be accounted for in the area in question, which are not explored properly or whose traceline is not known.

Increased attention is required in the environment of power or communication lines being in use (overhead or earth cables) as well as in the vicinity of gas pipelines. If possible, power must be switched off in the lines in question.

General health and safety provisions for the hoisting and handling of loads must be observed when works are performed with cranes.

It is STRICTLY FORBIDDEN to stay inside the hoisting zone of cranes, or under hanging loads. The hoisting operations must be led by a responsible leader or craneman; hoisting of loads may start only when this person indicates so; this is applicable for the performing of any other operations.

It is the craneman or the leader who controls the works who should command (in accord with the signals provided by the person who does the job e.g. the positioning) that the load can be lowered, or the hoisting power should stop or start; when an „empty hook“ is lifted, care must be taken to ensure that it should not cause damages (by swinging) to already installed mechanical equipment.

It is FORBIDDEN to stand on the reinforced concrete unit during the process it is lifted in.

Loads should be moved very slowly; the structure's weight is several tons, therefore it has a high inertia.

In the tight space that occurs in the work pit, work must be done very carefully so that the structure should not squeeze anyone to the work pit wall during the positioning process.

It is forbidden to stand or jump on the top of the mechanical parts installed into the reinforced concrete unit, or on the theft-preventing cover plate, and it should not be exposed to any other loads, as this may cause accidents or damages.

Protective gloves and protective helmets must be used when work is performed.

GENERAL OPERATION AND MAINTENANCE

INSTRUCTIONS – ENVIA TRP

INTRODUCTION

This present operation instructions contains general information on the operation of sludge trapping and mineral-oil separating equipment type ENVIA TRP, manufactured and distributed by PURECO Kft.; it provides support to the operator of the equipment, enabling it to carry out this task even on its own safely from the environmental perspective. If the provisions of this document are met, the distributor undertakes to warrant the compliance of the effluent with the relevant provisions.

Light-liquid separator equipment are responsible for cleaning waters contaminated by mineral oils or by settling or suspended particles before such waters are introduced to their respective receiving bodies. Regular inspection and maintenance are preconditions for the effective operation of the equipment. The responsibility for damages due to insufficient or a completely missing maintenance and inspection shall rest with the operator, therefore you are kindly asked to carefully study and observe the provisions of this document. The operator is responsible for the surveillance of the equipment, so these tasks must be carried out even if the regular (6-monthly) maintenance is outsourced by a contract to Pureco Kft.

An anterior bottom and a covered ditch section constructed in front of the equipment are also parts of the process; these parts function as a settling area and a storage facility during the operations; it is important to construct these parts in accordance with the drawings, as they must be dimensioned in accordance with the expectable hydraulic loads and loads due to contaminants. A design aid is available for the dimensioning work. A final weir is installed as part of the equipment; this weir dams up the water on the upstream part of the ditch or water course; this way it creates the above-mentioned, natural storing and settling area, whose dimensions, length and volume, depends primarily from the design/slope of the ditch; this is made complete by a drift-trap „box“; this box should be installed under the flow bottom level of the ditch, made from prefabricated pavement elements for ditches and watercourse beds. The useful volume of this drift-trap box should be equivalent (in m³) with 1/100 of the rated capacity of the planned equipment, specified in l/s. The equipment, cooperating with the storage tank before it and with the drift-trap box work on the principle of separating physical phases; materials lighter than water flow up to the surface already in the storage area; materials, heavier than water settle down. The process components made in the equipment do not allow these materials to leave or to flow away through the equipment towards the saved side. After the installation is complete, construction debris and earth fallen into the equipment must be removed; with this the equipment is ready for operation.

The loads occurring as a result of the composition and the volume of wastewater must always be in compliance with the design- and dimensioning values.

For the cleaning of panelled surfaces, neither chemicals nor such agents that cause oils to emulsify or to get solved should be used. This equipment is not designed to retain detergents („washing agents“) or materials harmful to waters (e.g. acids, alkali, or mineral salts).

DESCRIPTION OF THE OIL SEPARATOR EQUIPMENT

The separator equipment is installed in the way of stormwater flowing towards the receiver water course, typically in open-surface, paved channels or ditches. A prefabricated reinforced concrete unit accommodates the equipment; this element has an inlet side suitable to receive contaminated storm waters, joining to a drainage ditch section; it has an interim space suitable for separating light liquids, and it is also equipped with an outlet side to let treated water to flow away; its task is to create the dammed-up water-level necessary for the operations; the interim space is equipped with a filter insert.

Operating principles:

The stormwater to be treated flows through a lamellar frame (that can be pulled out for maintenance) located on the inlet side of the filter box; the lamellar frame has the following functions: energy-breaking; protection against frost and shading (protecting the coalescent filter material against UV-radiation).

The three main parts of the lamellar frame are the pull-out handle, the holding frame and the lamella sheets.

After that the water flows through the coalescent filter material that binds suspended micro oil drops that cannot flow up; it binds them on its surface due to its oilphylic and hydrophobic properties; when a sufficient number of micro oil drops are present and they are bound in sufficient vicinity, they coagulate to be an oil drop large enough to be able to flow up to the surface; the water flowing through the filter causes such drops to flow up on the other side of the filter.

The filter box has a self-supporting frame structure, which is made stronger by submerging wall(s) and weir wall(s), which are a must from the process perspective too.

The complete surface of the filter box is covered by a corrosion-proof steel shell. There are handles that serve the purpose of lifting out the filter box from its place. The water level inside the filter box is permanent, ensured by the last weir wall. The submerging wall(s) hang into the permanent water level; their function is to retain light liquids that float on the water surface. The role of the last weir wall could be played by a prefabricated reinforced concrete receiver structure, equipped by an appropriate weir edge, which is expressly intended to accommodate the filter box. Incoming water is spread inside the concrete structure in order to ensure that the loads by water are distributed over the total sectional surface of the filter box; as well as the concrete supporting blocks, made inside the concrete structure, should take up the water pressure the filter box is exposed to.

Sub-assemblies:

Prefabricated, reinforced concrete receiver unit:

This is a reinforced concrete structure, prefabricated at the manufacturing site, suitable for receiving the complete filter unit; it is suitable for connecting to the drainage-ditch section, and it carries the last weir wall that is indispensable from the process perspective. This unit is made in a design and size that meets the desired treatment efficiency requirements and the water flow volumes to be treated. When the water flow is more than the design water flow, excess water tip over the filter box; for this reason at least one row of concrete ditch-pavement panels must be installed, in order to protect the slope, at those sides of the prefabricated reinforced concrete receiver unit, which is parallel with the flow direction; also the narrowed-down parts of the ditch, necessary because of the installation of the reinforced concrete structure, should be provided with an appropriate pavement.

Dammed-up space and drift-trap box:

The characteristics of the space in which the water is swelled up by the weir wall of the prefabricated reinforced concrete receiver unit is that it creates an open-surface water-area and, at the same time, it has a longitudinal settling effect and a flow-balancing effect. The advantage of open-surface water storing is that it makes possible the departure of volatile contaminants washed down from the road pavement; further, the solar UV-radiation facilitates the degradation of hydrocarbons that flow up to the surface in the storing area. Through active evaporation the water level in the storing area gets lower, even to such an extent that settled drifts come out to the dry atmosphere (it may even dry out), which considerably simplifies the removal of drift from the drift-trap box; the quantity of hazardous waste to be disposed of lessens, as well as the fees of transportation and disposal in a landfill. Inside the dammed-up area, the water-bed must be paved up to the maximum, swelled-up process water level, and in a length of at least the length of the drift-trap box.

Cover plate to protect the structure against theft

There is a hazard of theft or injuring the filter box made from corrosion proof steel; for this reason we have equipped the unit by various mechanisms/parts that protect it against theft. One of such solutions is a cover plate (to protect the structure against theft) that covers the filter box over its top, and prevents it from catching the eye by its shine when viewed from the road; this plate also functions as a physical barrier for the removal of the filterbox. The cover plate is connected to the prefabricated reinforced concrete receiver unit. We fix also the filter box itself to the receiver reinforced concrete unit by bolts at plural points.

Flow-breaker lamellas:

At the point where the flow enters the treatment system, a flow-breaker is installed, which can be lifted out, but it cannot be removed from its place (see: the maintenance chapter). It has a construction that ensures that the energy of water is broken, and the flow is guided to the proper direction. As the water flow slows down due to the flow-breakers, coarse granules, sand, and sludge (eventually with adherent oil drops) settle down to the bottom, or into the drift-trap box, as they are heavier than water. The lamellas act also as the first delineating and supporting structure for the filtering insert.

Coalescent filter:

The water distributed by the flow-breaker lamellas flows evenly onto the surface of the filter, over the whole cross-section. The insert works on the coalescence principle: it retains suspended particles together with the oil contaminants that stick to such particles; these are stored inside the filter material; it also causes the micro oil droplets being in the suspended phase to cohere to its surface; then, after an appropriate size of oil drops is reached, it causes them to flow to the surface. The filter-insert material has a turquoise blue colour, which changes its colour due to the retained materials; the filter insert must be replaced by a new one when its original colour cannot be restored after washing.

Sludge-retaining wall:

The oily sludge that coheres to the filter material, and heavier than water, passes downwards in the filter, and collects at the bottom of the filter box. It is prevented from drifting away with the flowing water by an installed sludge-retaining wall.

Submerging wall:

This is a structurally integrated element; its task is to retain the oil caused to flow up by the filter insert, inside the dead flow area that occurs in front of the filter insert and between the insert and the submerging wall.

Weir area:

The flowing water enters another labyrinth, where, flowing through the combination of the weir- and submerging walls, its energy gets further reduced, and flows away.

Secondary, additional filter:

Its installation/application is justified when the water is discharged into receiving waters with stricter limit values, or when the installation site is exposed to increased risks (most probably the entering water is more contaminated). The filter insert material is identical with that of the above-mentioned filter; it plays a role in the further treatment of already treated water. It also provides additional safety for the receiver in those cases when the primary filter gets saturated, or when the incoming water has a higher velocity or a higher contamination level.

Weir wall and outlet channel:

This is the point at which the water leaves the process; the weir wall connects to the ditch on the outlet side, and it ensures a water level necessary for the functioning, inside the equipment. On the outlet side, a water-jump emerges after the weir wall, therefore the ditch must be paved in a length of at least 3 to 4 meters, up to the height of the maximum swelled process water level.

There are several variants for the process design of the equipment:**ENVIA® TRP**

By using a prefabricated reinforced concrete receiver unit (it is not necessary to have a final weir wall placed in the filter box, as its functionality is ensured by the reinforced concrete receiver unit):

Coalescent filter in a single layer

- Flow-breaker lamella
- Coalescent filter
- Submerging wall
- Weir wall integrated to the concrete structure

Coalescent filter installed in two layers

- Flow-breaker lamella
- Coalescent filter I.
- Submerging wall
- Weir wall
- Coalescent filter II.
- Submerging wall
- Weir wall integrated to the concrete structure

ENVIA® BOX

Installed in an already existing reinforced concrete receiver structure, for instance when a previously built perlite-type oil trap equipment is replaced; in such cases, when the existing reinforced concrete receiver unit is kept, the final weir wall placed in the filter box needs to be used, as the existing reinforced concrete receiver unit does NOT ensure that functionality.

Coalescent filter in a single layer

- Flow-breaker lamella
- Coalescent filter
- Submerging wall
- Weir wall

Coalescent filter installed in two layers

- Flow-breaker lamella
- Coalescent filter I.
- Submerging wall
- Weir wall
- Coalescent filter II.
- Submerging wall
- Weir wall

MAINTENANCE AND OPERATION:**General inspection:**

the installed equipment must be visually inspected once in every 3 months. During the inspection the following must be checked:

How much is the drift-trap filled up,

Is there a floating oil-contamination on the surface of the storing area (is the water-surface iridescent)?

Is the anti-theft cover plate at its place? As it intact and unharmed?

Are there any debris or drift caught on that surface of the equipment that faces the flow (e.g. branches of trees, floating material, PET-bottles, nylon-bags, etc.)?

Can the water flow unimpededly through the equipment?

Any debris or drift caught by the flow-breaker lamellas must be removed on the occasion of the inspection. The anti-theft cover plate should be removed from its place, and the moving part(s) must be checked (flow-breaker lamella, and the secondary filter frame). By lifting these parts out, the filter inserts can also be checked visually.

In accordance with the contamination of the filter inserts, the amount of drift stored by the drift-trap, and the presence of a floating oil film on the water surface, the date of the maintenance works and of filter cleaning must be established (immediately, within 1 to 2 weeks, within 1 to 2 months, or nothing needs to be done until the next quarterly inspection).

Settled contamination, floating oil and large particles:

The separated and settled sludge must be removed from the bed of the water course/ditch, or from the drift-trap box from time to time, but at least once a year, according to the findings of general, 3-monthly inspections. With view to the fact, that the removal frequency, depending on the exposures, may be once a year (and the separated sludge may turn to be a hard layer in such a long time), it is not enough to remove only the liquid phase in such occasions. For the first step of cleaning, the floating light liquids must be removed from the storing area; these must be handled as hazardous waste. During the maintenance and cleaning works (to be carried out at least once a year.) it must be ensured that settled and hardened sludge and/or sand layers should be broken up and removed, and the whole system be cleaned. The annual maintenance, or the removal of settled drift should be scheduled to take place after a sunny and dry period; by this time the major part of floating hydrocarbons in the storing area will have been decomposed as a result of solar UV radiation, and the water level in the storing area has got lower due to active evaporation (even to such extent that the settled drift comes out to the dry atmosphere (it may even get dried). This may considerably simplify the removal of drift from the drift trap box; the volumes of hazardous waste to be transported is reduced, as well as the fees of transport and disposal in a landfill.

As part of the maintenance works, the lamellar guiding plates must be washed by a high-pressure washing equipment; the washing direction must be opposite of the water flow direction, that is, from the weir wall towards the drift trap box. At the inlet side, the contamination caught between or settled out to the lamellas must be removed; also, when the lamellar board is pulled out upwards, and fixed, the saved side of the lamellar board can also be washed conveniently.

During the operations, care must be taken to ensure an unimpeded inlet path; when there are large amounts of floating pieces of drift, it must be removed from the system.

Filter insert:

In the oil separator, the coalescent filter separates floating, free-phase (non-bound) oil droplets, as well as it retains the residual fine sludge that floats in an intermediate phase. This fine floating material, that adsorbs typically a microscopic oil film, adheres to the filter surface, and blocks it after a while.

The filter bodies must be taken out from their place, and their cleanliness must be checked; these tasks must be carried out during the quarterly general inspections or more frequently, depending on the utilisation levels, and on the basis of operating experiences. When, during the inspections, the filters are found to be saturated by greyish-brownish fine sludge (a thin, oily fine sludge trickles down from the filter), then the filters must be washed through, under any circumstances. First the main filter insert must be pulled out, then the flow-breaker lamellas must be lifted out by a handle, and a securing pin must be inserted at the outlet side; then the insert should be tipped out from its frame to open the way for washing. You are kindly asked to exercise care during such works, in order to avoid injuries. After these actions, the filter insert can be cleaned by the following method.

The removed filter should be rinsed through by using cold water through a garden hose (it is FORBIDDEN to use high-pressure washing equipment or steam-shavers). The washing may take place in the vicinity of the inlet point, either on a paved slope that belongs to the drift-trap box section, or on the sole of a paved ditch-section in front of the drift trap ditch. After cleaning, the filter can be used again. It is practicable to wear rubber boots when washing the filters, by continuously trampling upon the filter. With view to the fact, that this is one of the most important components of the system, their cleanliness and/or continuous inspection is very important. When the filter is clogged by sludge, water cannot flow through it anymore; even with an increased pressure in the oil separator, the water cannot flow through the filter with proper velocity, therefore the water level keeps rising, resulting in water filling up the section in front of the equipment; in extreme cases the contaminated water does not flow through the technology, instead it may leave untreated over the filter box to the saved side. The saturation of the filter insert may be such, that the contamination retained by the filter insert gets washed out to the clean-water side, and leaves the equipment.

Please **do not let the equipment get to such a condition** (non-operational condition, improper treatment). Please note, that the operator can be called to account in such cases!

CLEANING THE FILTER BY SOLVENTS OR BY CHEMICALS IS FORBIDDEN AND UNNECESSARY!

It is not recommended either to use high-temperature steam shaving for cleaning, as it may cause damages to the filter. It is recommended to replace the filter once in 2 to 4 years (depending on its utilisation level), or to have it replaced by the supplier.

The separated oil can be removed by a mobile oil skimmer equipment (this is carried out by the supplier under a maintenance contract).

After the cleaning/washing operation is complete, the insert should be tipped back to its place, then the lamellar board should be lowered and fixed at its own position.

When stormwaters need to be treated to achieve stricter treatment limit values (SZOE < 2 mg/l), then a secondary filter must be installed in the system. In a two-stage treatment equipment a secondary filter is installed. The frame that holds the filter should be lifted out by a handle on the frame; after fixing it, the insert can be tipped out from the frame (after the delineating grill has been removed). The cleaning process is the same as for the main filter.

When the inserts are put back to their place, care must be taken to ensure that they sit exactly at the place they are intended to.

In the cleaning process, also the prefabricated reinforced concrete receiver unit, and the stainless steel fittings must be washed down. For these units it is recommended to use high-pressure cleaning equipment, by continuously sucking away the water used for washing as well as the contamination. In the case of TRP type equipment, a mobile pump can be placed in the area in front of the weir integrated into the concrete unit, on the outlet side; with this pump, the water produced during washing and considered to be a hazardous waste, must be recirculated to the drift-trap box, already cleaned.

EMERGENCY EVENTS

If an emergency event occurs in the water-catchment area of the water that goes into the equipment, the equipment is able to contain spilled hazardous wastes, as a result of its combination of submerging and weir walls, up to the volume of the storing area in front of the equipment; anyhow, immediate action must be taken, the retained materials must immediately be removed, and an overhaul of the equipment (as described above) is needed. Please, give us a call!

The general accident-prevention rules must be observed in the maintenance works of the equipment, with special view to the provisions for the treatment of hazardous waste. Maintenance works must be carried out only under supervision!

Increased attention must be paid to the danger of skidding! **During maintenance, it is strictly FORBIDDEN to smoke or to use naked flames!** When work is being carried out, the equipment must be cordoned off!

The material removed from the oil separator (oil, oily sludge) is considered to be a hazardous waste, which must be treated in accordance with the relevant provisions! Such materials must be disposed of by such companies only that hold authoritative licences for such operations. The Employer or the responsible Operator shall be obliged to check if such a licence is held by the assigned company! An operation log must be maintained on the operation of the equipment, in which the following data must be recorded: inspections performed, maintenance and other operations; the events when hazardous wastes are disposed of, and the removed quantities.

Should you have any questions in connection with the operation of the equipment, please contact our colleagues at:

